



Shop Solutions



Since 1958, **Caddie**® has applied expertise and intelligence to design reliable high level products. Excellence, comes first and foremost from a no compromise approach to materials and products, as well as from the expertise of people who can offer every customer the best solution.

Founded in 1928, **Caddie**® is a worldwide well-known family company established in Drusenheim, Alsace. Historical partner of international retail, **Caddie**® is the French brand of reference. We offer quality equipment for retail and logistics.

The major retail trade has changed constantly in fifty years. At the same time, **Caddie**® has demonstrated its ability for constant change through greater personalization of the products based on observing users and the consumption experience.

From design to manufacturing, our experienced teams rely on 50 years of know-how to create the worldwide standards of equipment.

Our expertise is also to support our customers by deploying innovative customized solutions for each business line.

This exceptional approach helps to perpetuate the legend and confirm **Caddie**® status as a leading international partner of major retail outlets.

Caddie[®] French brand of reference (1957).

A synergy of industrial competences specialized in metal-plastic technologies. Based in Drusenheim, and located in Alsace since 1928.

Caddie brand is promoted worldwide thanks to a sales network with more than 130 offices.

In 2016, **Caddie** invested in a new production plant in Dettwiller.

Caddie[®] is part of the excellence of French know-how

Caddie received 2017 the label « Entreprise du Patrimoine Vivant » (EPV). This label is a mark of recognition of the French State, put in place to reward French companies for the excellence of their traditional and industrial know-how.

Customized Solutions



Shopfitting must do the selling

In no store is equipment so important as in the self-service, where equipment often serves instead of sales staff, where its appearance takes the place of personality, and where its display takes the place of sales talk.

Caddie personalized shop solutions provides a strong incentive to buy for successful sales.

90 years of know-how

Historical partner of international retail, Caddie® is the French brand of reference to create the worldwide standards of equipment. Our expertise is also to support our customers by deploying innovative customized solutions for each business line.



Bespoke and modern shopfitting architecture

44% of consumers say that they will likely become repeat buyers after a personalized shopping experience with a particular company (*)

From the draft concept to the design, our project managers come up with tailored solutions to the retailers exact shopfitting requirements, to increase sales and customer loyalty to your brand.

Our target : your sales success thanks to smart combination of materials and design, to increase attractiveness of your products.

(*) According to the 2017 State of Personalization Report of more than 1,000 U.S. consumers

caddie

Quality since 1928



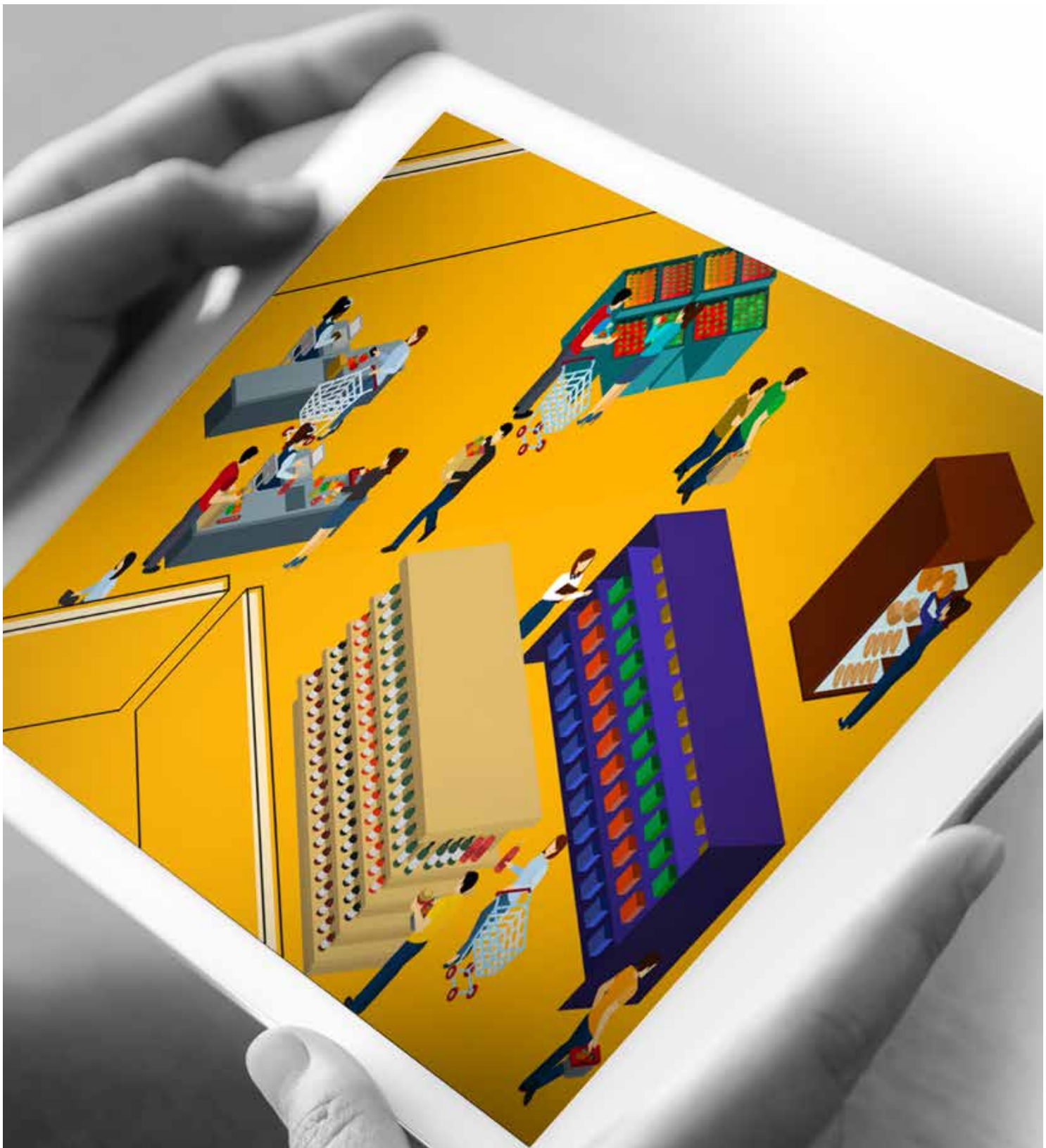

Customized Solutions

Our specialized Caddie teams manage original and unique projects, customized according to your needs. These projects are entrusted to us by our clients or by architectural firms. Whatever their origin, they are optimized by our engineering and design department, materialized in our ultramodern factories and installed by our specialized teams. We use the latest generation materials and put all our know-how to work for a high-end finish.

Caddie ExpoLine



06-17

Caddie Veggie



18-25

Caddie Bakery



26-31

Caddie WineExpo



32-37

Caddie Checkout



38-41

Caddie ExpoLine

Caddie.Expoline shelving creates spaces full of character.

With a multitude of design possibilities and a fascinating choice of materials, coatings and colors, Caddie ExpoLine gondolas adapt to your spaces or create new ones in an instant.

Our shelves are known for their quality and their resistance to the load, they are very stable.

Caddie.Expoline presentation systems combine aesthetics, functionality and cost-effectiveness.

It is thus possible to create very easily ergonomic sales areas favoring shopping.

The hygiene and beauty sectors can be highlighted with LED lighting and special materials.

Use the Caddie teams to rethink your store and increase your sales!



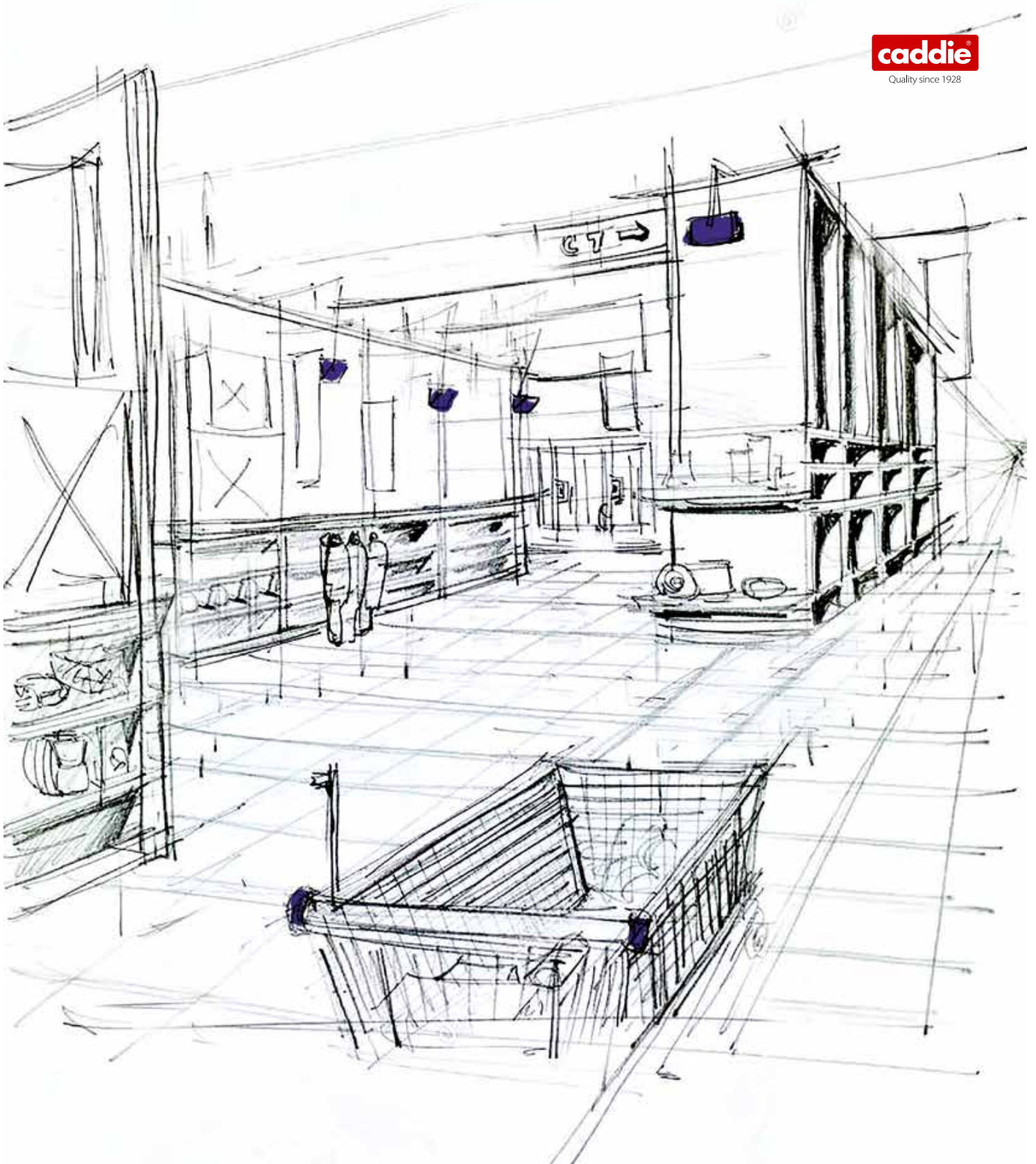



Promotion Baskets Medium Range

Promotion Basket Medium 800x800 H780

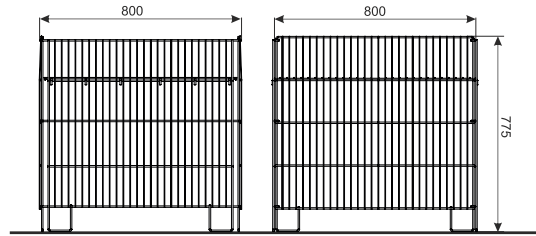

Ref. 6 683 00 03

Promotion Basket Medium 550x550 H770

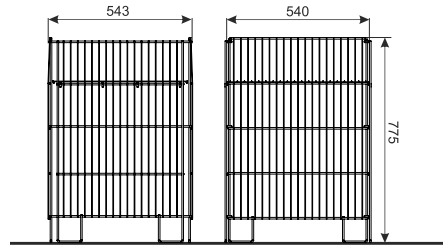

Ref. 6 683 10 03

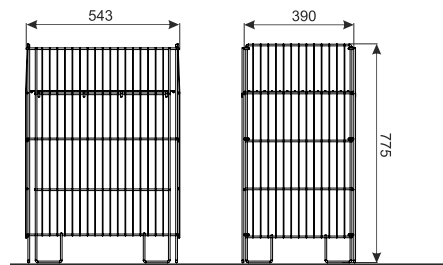

Promotion Basket Medium 550x390 H770



Ref. 6 683 20 03



Accessories Promotion Baskets

	Basket 800x800 H780	Basket 550x550 H770	Basket 550x390 H770
Base	6 683 00 03	6 683 10 03	6 683 20 03
MODULARITY +			
 Shelf	Standard		
 Maximum loading	50 kg	50 kg	40 kg
 Folding basket	Standard		
Coating : Electrolytic zinc coating with varnish			

Folding structure - Promotion Baskets Medium



Shelf - Promotion Baskets Medium





Promotion Tables Large Range

Promotion Table Large 1200x800 H850/650

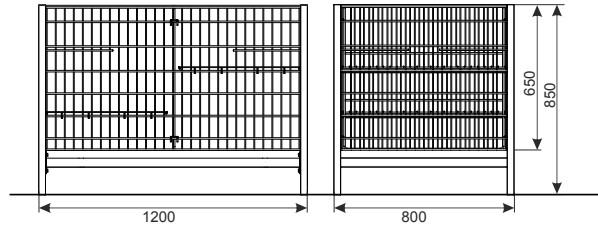

Ref. 6 682 20 03

Promotion Table Large 1200x800 H850/400

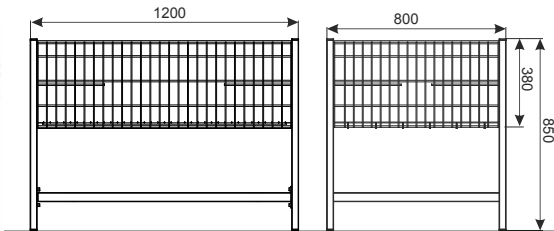

Ref. 6 682 40 03



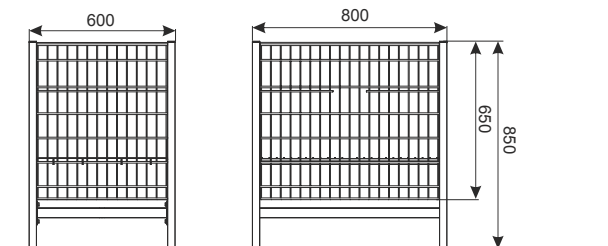

Promotion Table Medium 800x600 H850/650



Ref. 6 682 60 03



Accessories Promotion Tables

	Table 1200x800 H850/650	Table 1200x800 H850/400	Table 800x600 H850/650
Base	6 682 20 03	6 682 40 03	6 682 60 03
With casters	6 682 25 03	6 682 45 03	6 682 65 03
MODULARITY +			
 Divider		Optional	-
 Overhead attachment « Shelf »		Optional	-
 Overhead attachment « Basket »		Optional	-
 Exposition grating		Optional	-
Coating : Electrolytic zinc coating with varnish			

Divider H-270 to the display table 1200X800

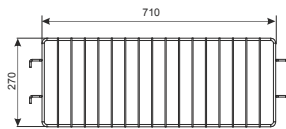
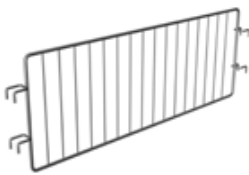

Ref. 6 682 21 03



Overhead attachment Shelf

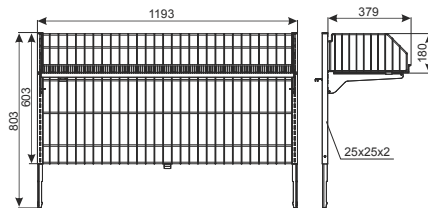

Ref. 6 682 22 03



Overhead attachment Basket

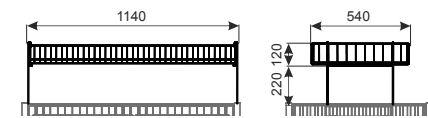

Ref. 6 682 23 03



Exposition grating 1200x600 to the display table

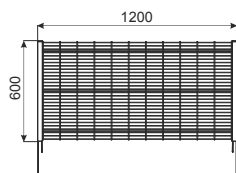

Ref. 6 682 24 03



Stackable Caddie.Baskets

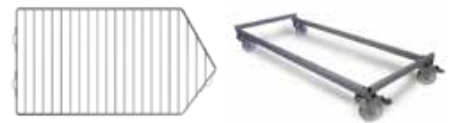
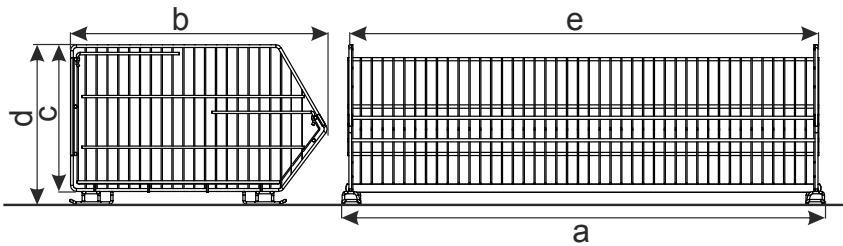
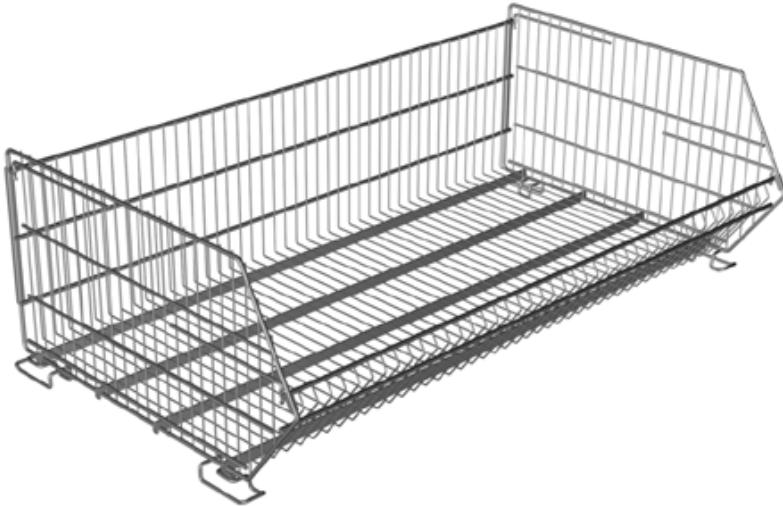

REFERENCE	OVERALL DIMENSIONS IN MM					VOLUME IN DM3	DIVIDER	MOVABLE CHASSIS
	a	b	c	d	e			
6 677 20 03	600	440	365	400	560	960	6 677 40 03	OPTIONAL
6 677 21 03	600	640	365	400	560	1400	6 677 43 03	OPTIONAL
6 677 22 03	800	540	365	400	765	1570	6 677 42 03	-
6 677 23 03	1200	540	365	400	1165	2370	6 677 42 03	-
6 677 24 03	1200	640	365	400	1160	2800	6 677 43 03	OPTIONAL
6 677 25 03	1230	700	365	400	1190	3140	6 677 44 03	-
6 677 26 03	1335	800	390	420	1295	4160	6 677 45 03	-

Product benefits

Standard finish: zinc coating with varnish.
 Technical data: The structure of basket made of spot welded wire.
 The bottom is reinforced with flat irons against deformation.
 Stacking feet made of wire.

Maximum loading:

(with equable spreading of the goods): single basket - 100 kg,
 3 stacked baskets - 100kg/50kg/50 kg.





Stackable and Foldable Caddie.Baskets

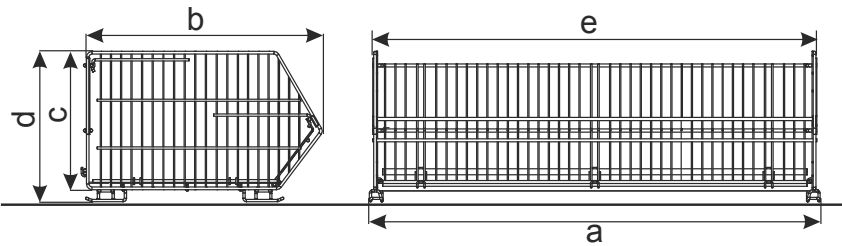

REFERENCE	OVERALL DIMENSIONS. IN MM					VOLUME IN DM ³	DIVIDER	MOVABLE CHASSIS
	a	b	c	d	e			
6 677 30 03	1240	670	385	420	1205	3200	6 677 46 03	OPTIONAL
6 677 31 03	600	620	365	400	560	1350	6 677 47 03	

Product benefits

Standard finish: zinc coating with varnish.
 Technical data: The structure of basket made of spot welded wire.
 The bottom is reinforced with flat irons against deformation.
 Stacking feet made of wire.

Maximum loading:

(with equable spreading of the goods): single basket - 100 kg,
 3 stacked baskets - 100kg/50kg/50 kg.



Mobile Stand

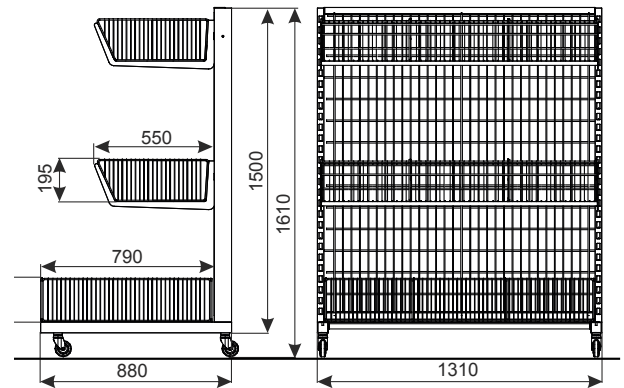

Ref : 6 682 80 03

Finish: zinc coating with varnish.

Technical data: Legs of sections, back wall of wire mesh: basket and shelf of wire reinforced by flats, basket hanged up in perforation leg frame, a bottom shelf fixed on foot frame. A possibility of adjust the angle of inclination of hanging basket.

Loading:

Total loading of stand - 200 kg.

Loading of hanged up basket - 50 kg.

Loading of bottom shelf - 100 kg.

Mobile Stand 2



Ref : 6 682 81 03

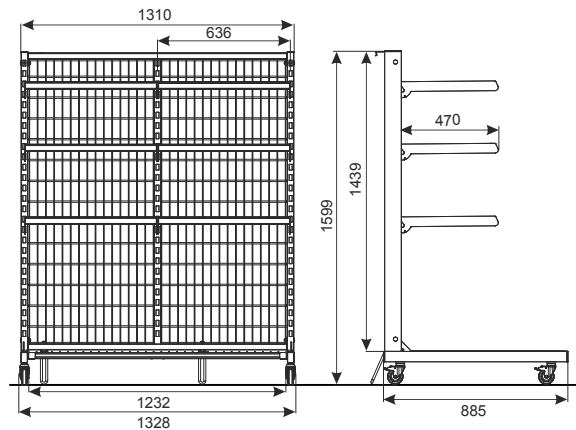

Finish: zinc coating with varnish.

Technical data:

- Construction made of sections and bars

- Lower shelf: made of wire, reinforced with flat iron, folding

- Upper shelf: made of wire, reinforced with flat iron, assembled to the rack with catch; length 466 mm; 2 shelves on one level, normally three levels are assembly on rack (6 shelves).

- **Swivel castors: 75 mm with brake; 4 pc.**

Maximum loading:

static loading of the shelving – 420 kg

dynamic loading of the shelving – 240 kg

loading of the bottom shelf – 240 kg

loading of one level of shelves – 80 kg

Shelving above



Ref : 6 682 82 03

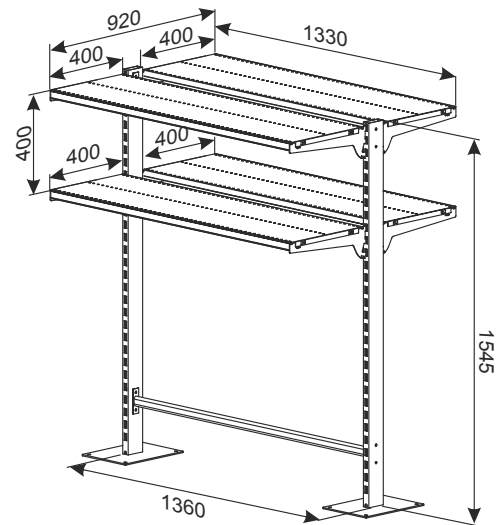

Standard finish: powder coated, zinc coated feet to the shelving.

Technical data: Legs made of section; metal shelves are assembled on brackets stacked into profiles. Whole is powder coated.

Maximum loading:

(with equable spreading of the goods):
shelf 430 x 1330 mm - 120 kg. on one shelf

Outdoor Gondole

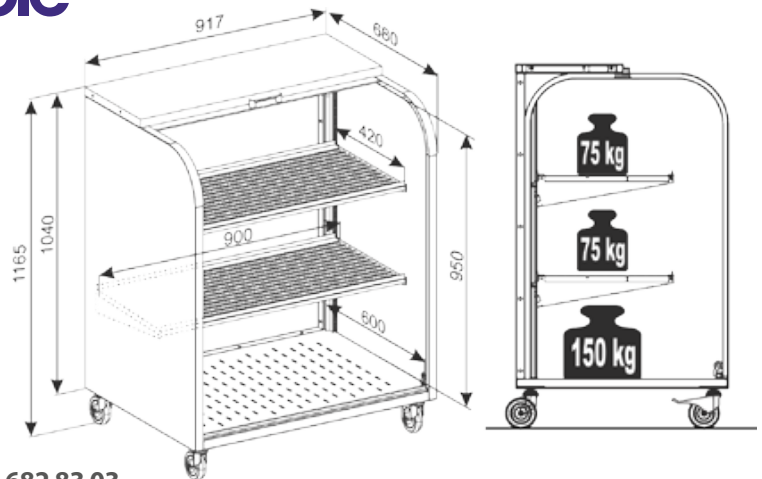

Ref : 6 682 83 03

Standard finish: electroplated with zinc and polyester powder coated.

Technical data: The gondola is made of metal sheet, sections and flat irons that reinforce its construction. It is equipped with an aluminum rolling shutter that has special plastic sliders, a push button type lock with a set of keys, four brackets, two perforated shelves for displaying of the goods and four polyamide wheels with a diameter of 100 mm (two of the wheels are equipped with brakes).

Maximum loading: (with equable loading): shelf - 75 kg,
bottom of the gondola - 150 kg.

In the option one can be install anchors for fixing to the ground or regulated feet instead of wheels.



Achievement



Projects carried out with our customers in collaboration with architecture specialists from our own design division. Installed by our specialized teams, they help keep the product at a maximum of density and present merchandise attractively.

Expertise





Solutions



Caddie Veggie

From store to home, your customers are looking for fruits and vegetables just picked, synonymous with great freshness.

That means almost infinite design possibilities and increased impact of your freshly picked crisp products for your customers.

We use the materials of your choice (wood, stainless steel, plastic) that fit perfectly into the desired buying atmosphere.

We can incorporate casters if desired so that you can rearrange your sales linens in the blink of an eye.

Solid and modular furniture from the **Caddie.Veggie** range is the key to your sales growth!





Double basket

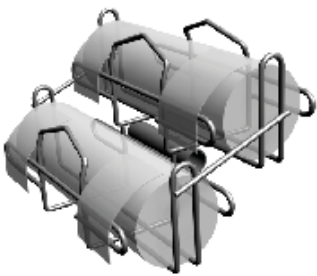
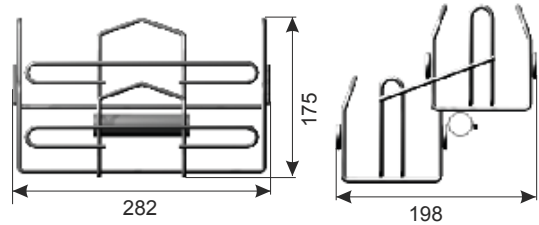

Ref : 6 683 02 03

Standard finish: zinc coating with varnish.

Technical data: Basket made of wire and tube.

Maximum loading: ca 10 kg.

Capacity of the basket:

- maximum diameter of roll 85 mm,
- maximum length of roll 260 mm.

Rack with basket

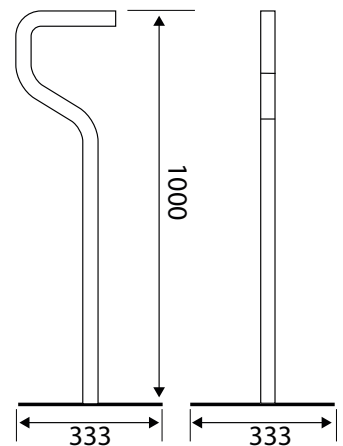

Ref : 6 683 03 03

Standard finish: zinc coating with varnish.

Technical data: Leg is made of the pipe, base made of plate. The basket is fixed to the rack by screwing the basket to the racks leg.

Maximum loading: ca 10 kg.

Grip with Tray

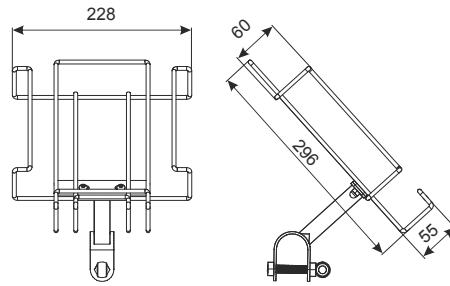

Ref : 6 683 04 03

Standard finish: zinc coating with varnish.

Technical date: Grip with tray is turned by screws. A tray made of wire. Grip is mounted on horizontal tube 40 mm through its application on the tube and tightening screw fixing.

An example of application – assembly on entry barrier:

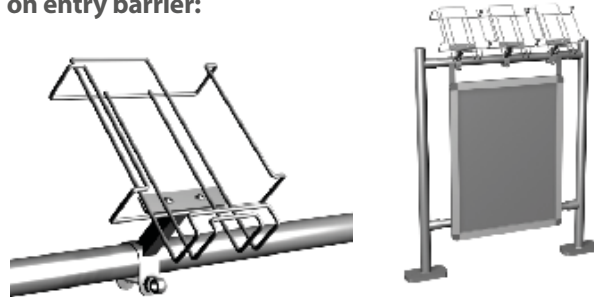

Mobile Flower Display



Ref : 6 683 05 03

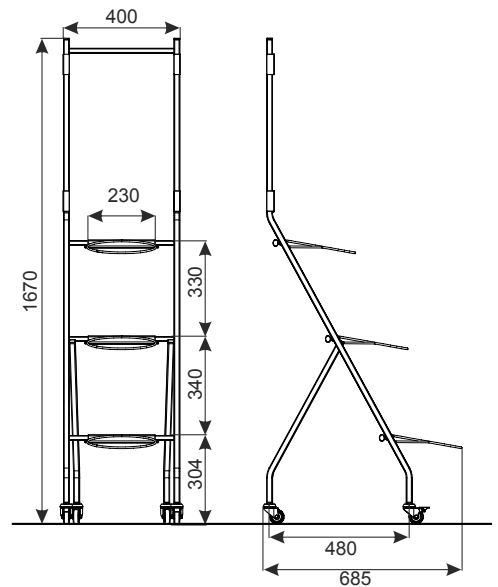

The stand on wheels for cut flowers is made of steel profile ,with 3 rims for buckets with flowers.

Standard finish: zinc coated or powder coated.

Vegetable display Medium



Folded position

Ref: 6 683 00 03

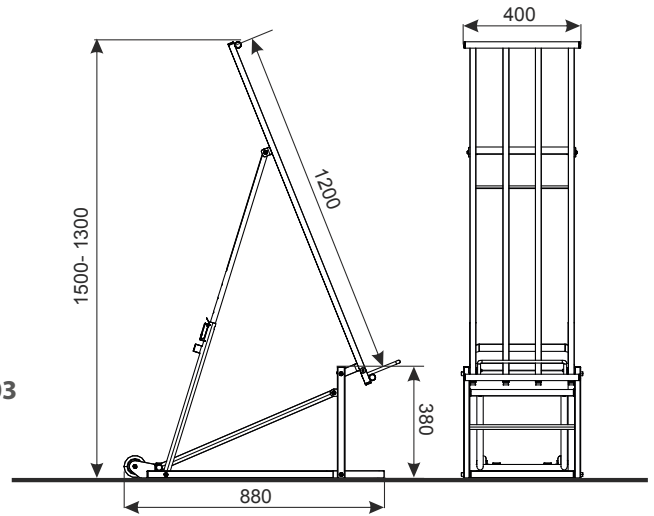

Stand is designed for exhibition and sale of fruits and vegetables placed on the boxes. On one rack, you can put 2 boxes.

Standard finish: zinc coated with varnish, optionally: upper frame powder coated.

Technical data: Rack made of sections and pipes; castors 80 mm. There is a possibility to adjust the tilt of the frame. Rack construction allows to folding a rack to the very small size.

Maximum loading: 75 kg.

Vegetable display Large



Folded position

Ref: 6 683 01 03

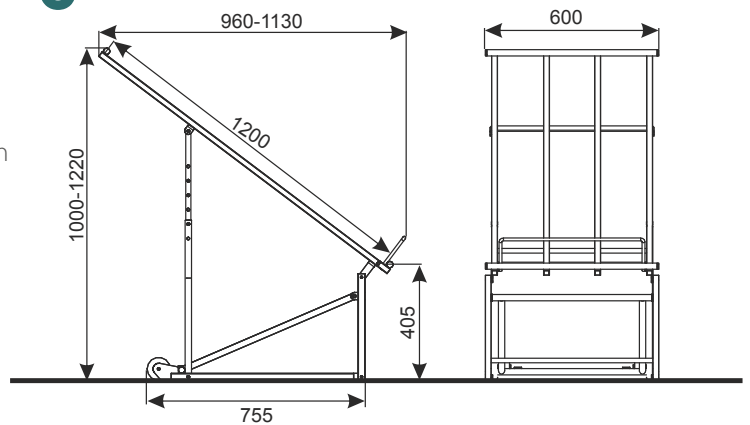

Standard finish: zinc coated with varnish, optionally: upper frame powder coated.

Technical data: Rack made of sections and pipes; castors 80 mm. There is a possibility to adjust the tilt of the frame. Rack construction allows to folding a rack to the very small size. Size of the folded stand: 1260x615x120 mm.

Maximum loading: 100 kg.



Vegetable Mobile display 3 shelves



Ref : 6 682 84 03

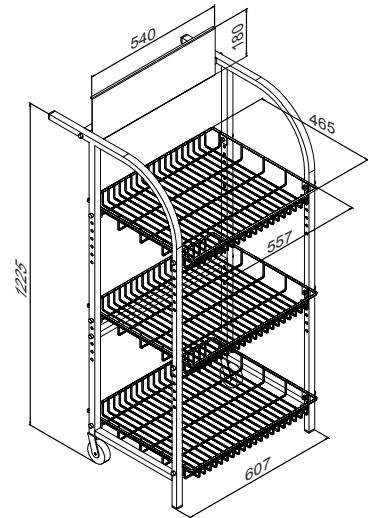

Standard finish: powder coated.

Technical data: The frame is made of section, wire shelves bolted to the frame, possibility of adjust the height of the shelves on the required level. Two wheels attached to the rear legs make it easy to move the rack.

Vegetable Mobile display 4 racks



Ref : 6 682 85 03

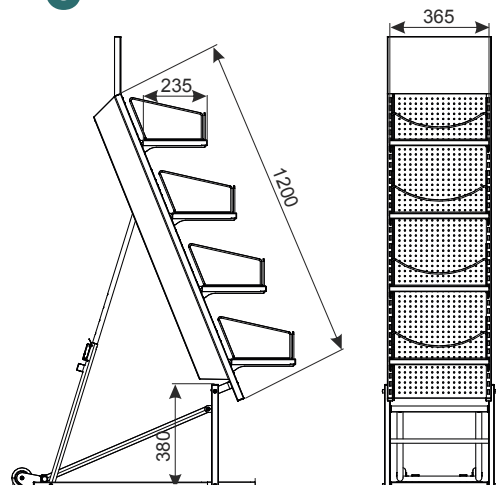

Standard finish: zinc coated with varnish, optionally: upper frame zinc plated + powder coated

Technical data: stand made of sections and pipes; masking frame made of perforated metal sheet; castors Ø 80mm, 4 shelves made of perforated metal sheet mounted on the stand with bracket.

There is a possibility of adjust the height of fixing the shelves and of adjust the slope of the frame. Racks construction allows for folding the stand to the very small size. Front stops on the shelves protect from sliding off the goods.

Maximum loading: 15 kg on one shelf.

Achievement



Excellence

Going to market and returning to the values of authenticity and freedom reflects the changes in purchasing and consumption behaviours. CADDIE® is responding to this new trend to purchase «as at the market» with Caddie.VEGGIE.



Solutions

Caddie Bakery

Fully customized solutions, Customer dedicated product development starting from concept and design, through mockups, technical drawings to ready made product. Wide variety of technologies and finishes: wood, plywood, aluminum, steel, integrated illumination as option, powder coating according to RAL Classic color swatch.

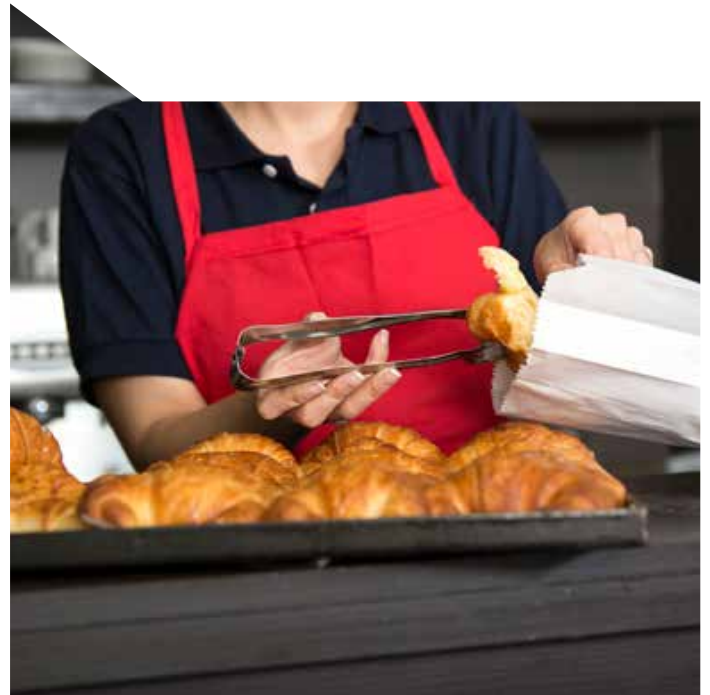
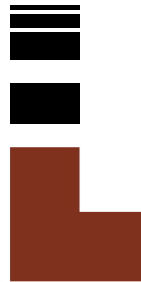



Bakery Furniture



Bakery stand based on 4 independent modules, easy setup on 1333mm wide bay. Color finish according to RAL Classic color swatch. Optional internal illumination of modules.

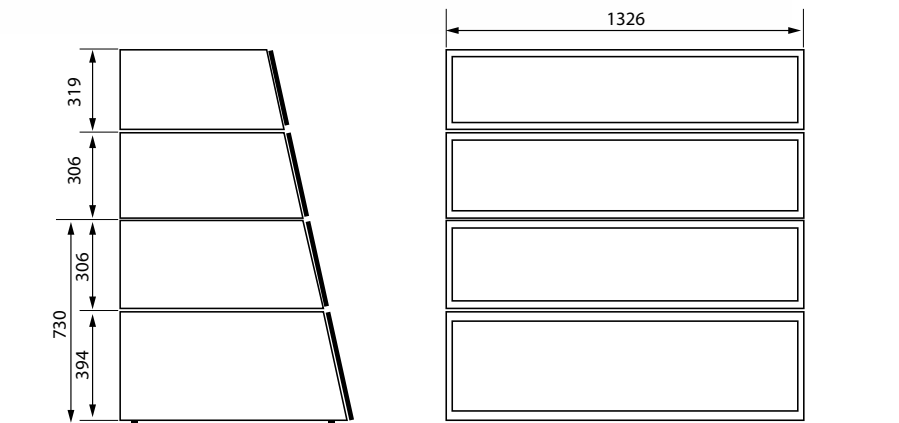
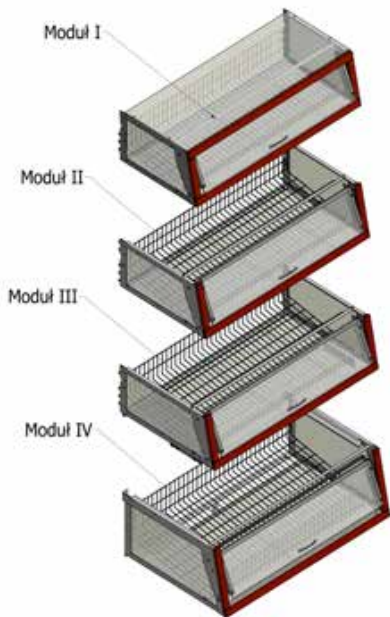



Promotion Tables Large Range

Promotion Table Large 1200x800 H850/650

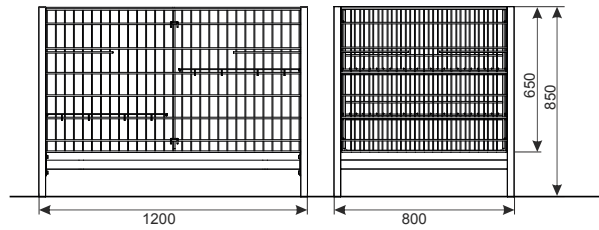

Ref. 6 682 20 03

Promotion Tables large 1200x800 H850/400

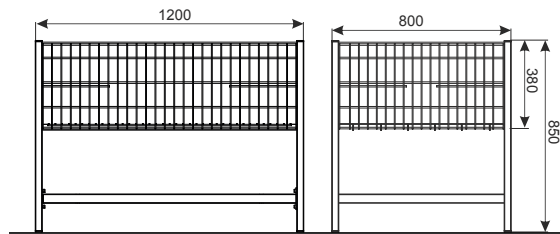

Ref. 6 682 40 03

Promotion Tables Medium 800x600 H850/650

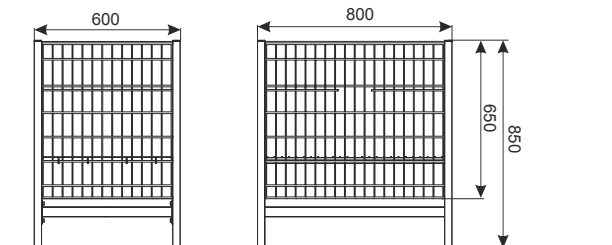

Ref. 6 682 60 03



Promotion Baskets Medium Range

Promotion Basket Medium 800x800 H780

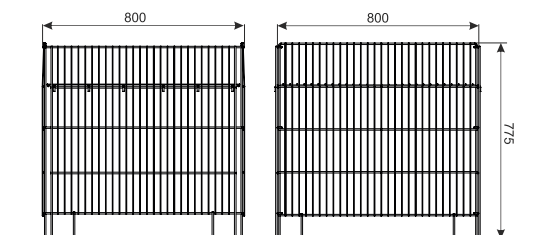

Ref. 6 683 00 03



Achievement



Place of outstanding lifestyle, mixing authenticity, modernity, quality products and technology.



Expertise



Solutions

Caddie WineExpo

Wines and spirits make the economic success of your point of sale. Increasing your volumes in this area is important for the growth of your store.

Caddie.WineExpo solutions highlight your wine selections in an atmosphere conducive to an instinctive purchase

Designed in a variety of materials (metal, wood, plastic) they can be equipped with latest-generation LED lighting to emphasize the purple and amber colors of your precious liquids

Call on our teams to rethink your wine department and put it forward.

Our interior designers and engineers will enhance your selections of wines and spirits and help you increase your profitability.



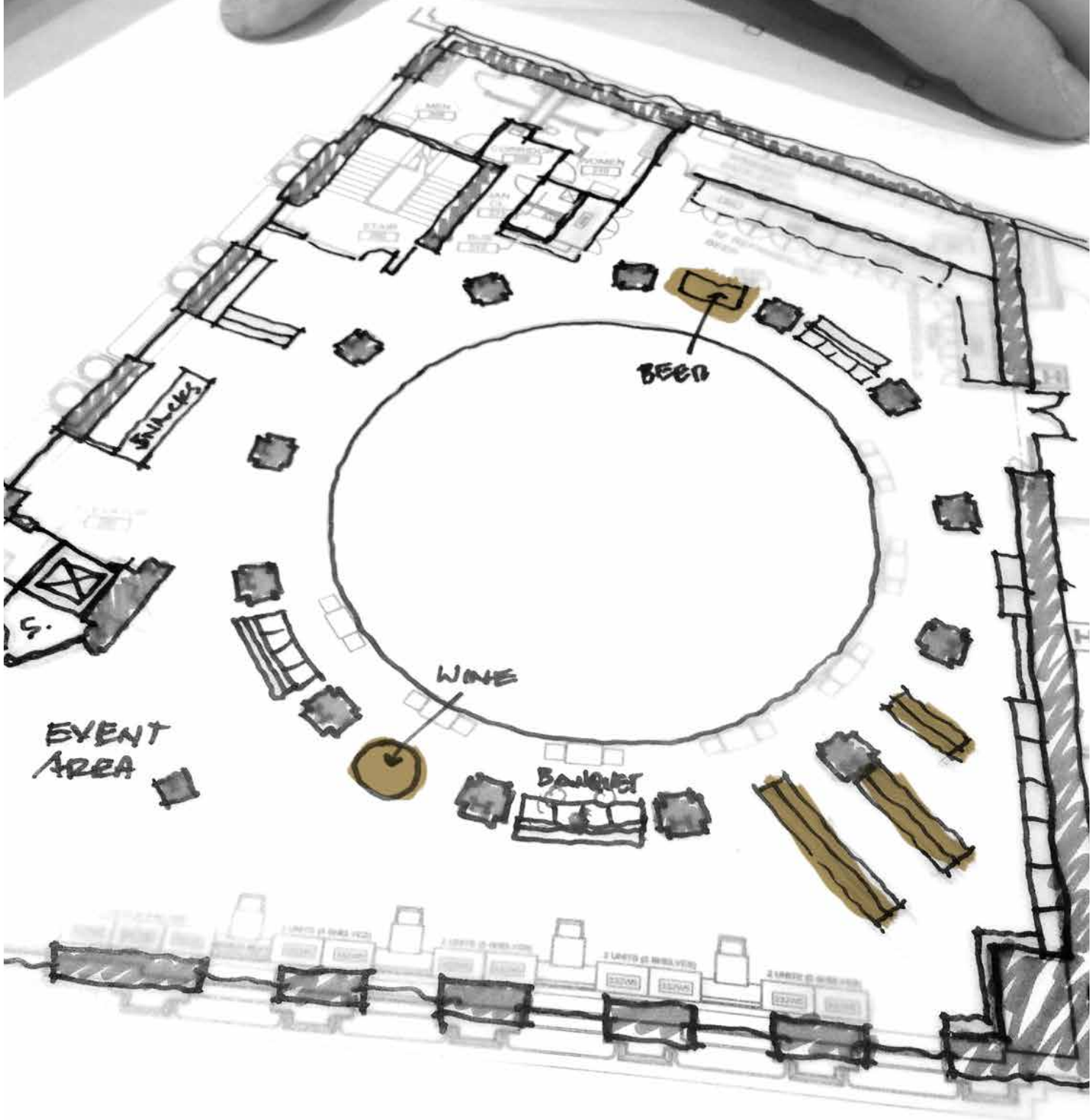

Bottle racks



60 BOTTLES
Ref. 9 913 60 03
 Dim.: L.510xD.365xH.1260 mm.



90 BOTTLES
Ref. 9 913 90 03
 Dim.: L.510xD.365xH.1900 mm.



120 BOTTLES
Ref. 9 913 80 03
 Dim.: L.800xD.365xH.1580 mm.

Caddie.Palett

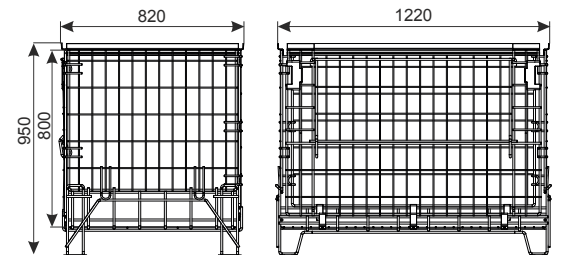

Ref : 4 696 86 97



Very handy and highly modular, the **Caddie®** range ensures stable stacking of open and folded boxes. When empty, the panels can be folded in the base.

Standard finish: powder coated.

Weight in Kg : 50 kg

Dimensions : 1200 x 800mm

Shelving above



Ref : 6 682 82 03

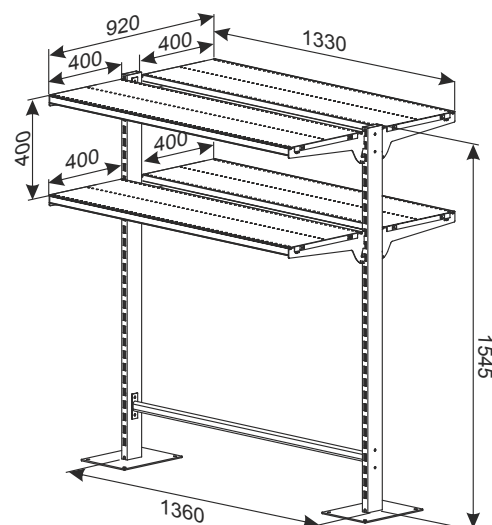

Standard finish: powder coated, zinc plated feet to the shelving.

Technical data: Legs made of section; metal shelves are assembled on brackets stacked into profiles. Whole is powder coated.

Maximum loading:

(with equable spreading of the goods):
shelf 430 x 1330 mm - 120 kg. on one shelf (with equable spreading of the goods).

Mobile display 3 shelves



Ref : 6 682 84 03

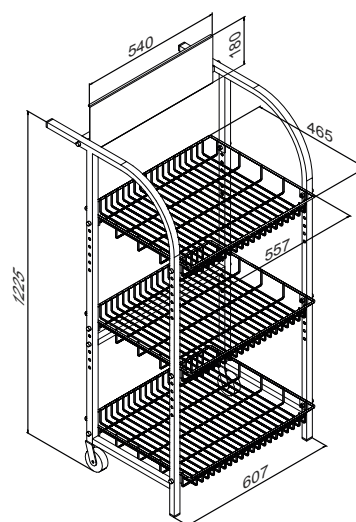

Standard finish: powder coated.

Technical data: The frame is made of section, wire shelves bolted to the frame, possibility of adjust the height of the shelves on the required level. Two wheels attached to the rear legs make it easy to move the rack.



Achievement



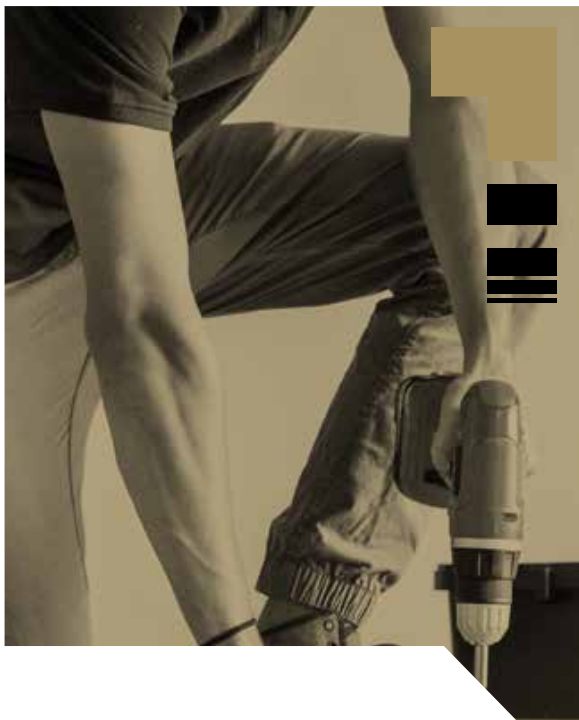

Reference

Fully customized solutions, Customer dedicated product development starting from concept and design, through mockups, technical drawings to ready made product. Wide variety of technologies and finishes: wood, plywood, aluminum, steel, integrated illumination, powder coating according to RAL Classic color swatch.



Solutions

Caddie Checkout

Checkout counters for small shops, mid and large size stores. Solutions based on wide variety of high quality components and functions.



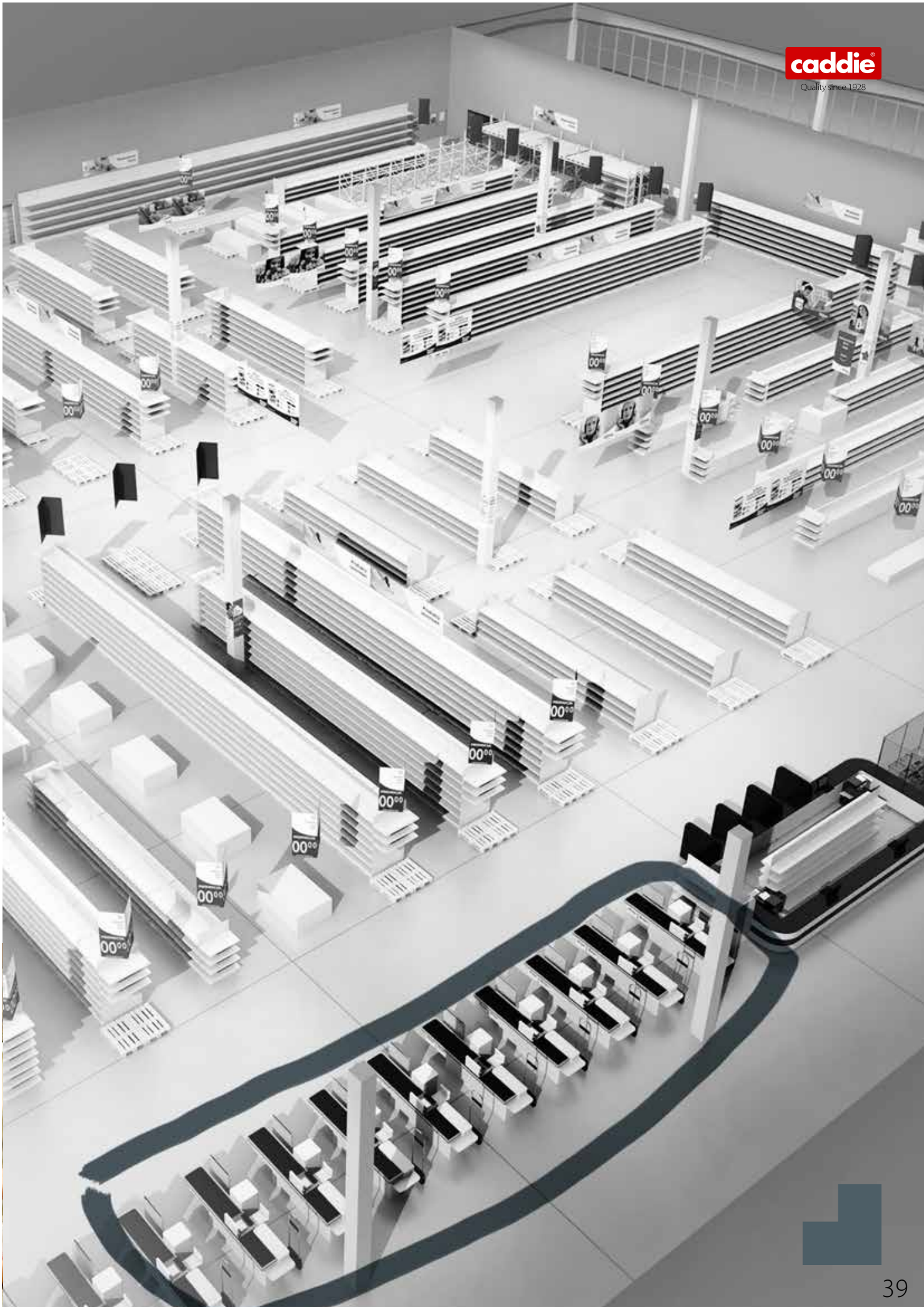



Achievement



Customized





Modern design and high quality of raw materials mixed with variety of color options and functions results in high number of variants. Optional build-in stands and/or head stands provide additional space for merchandise.

Solutions 

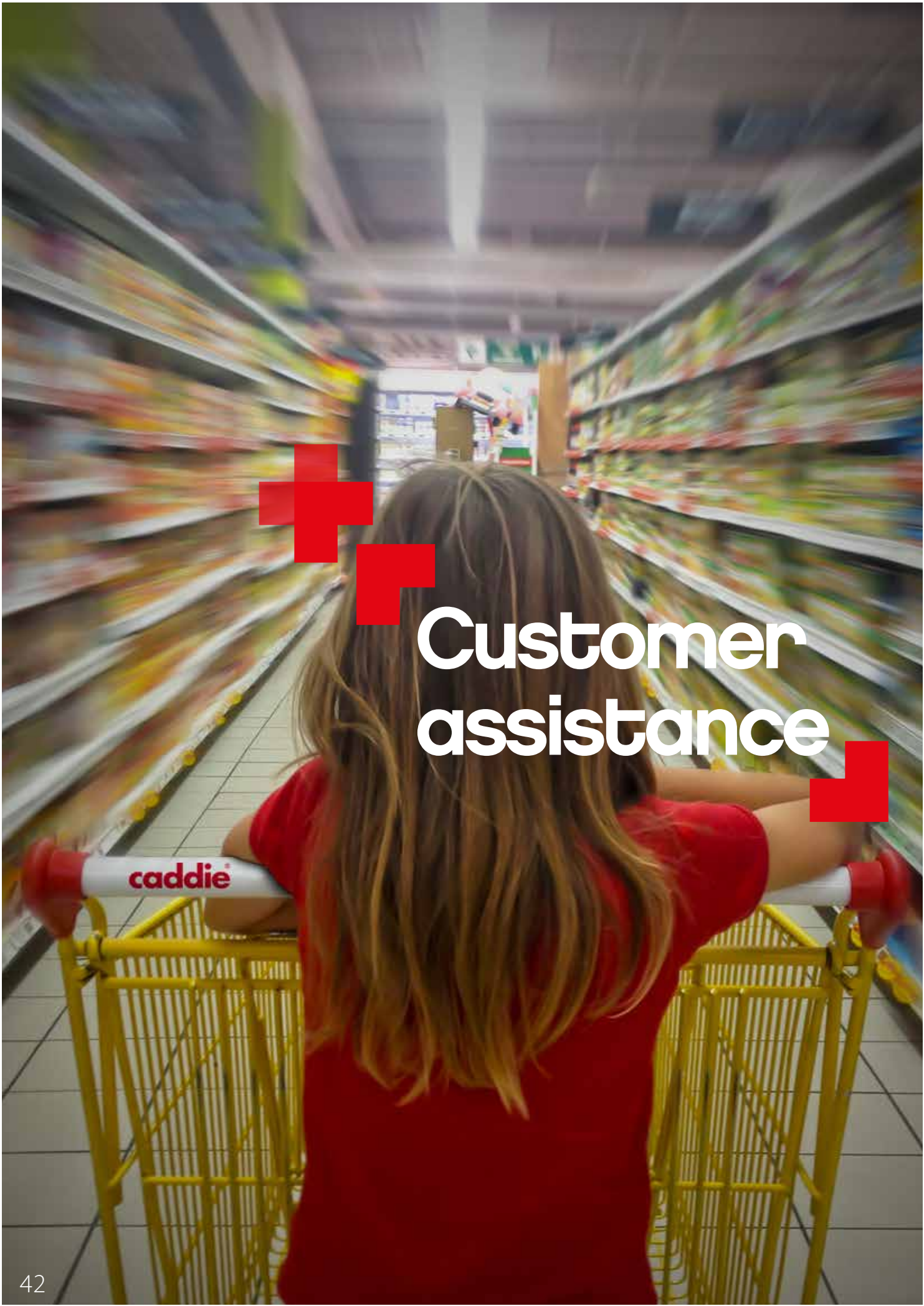

Customer assistance



Shop Catering



44-45

Service Point



46-49

Guiding



50-51



Shop Catering

Stores as places to live. Offering new instore experiences along the customer shopping path is a good way to attract and retain them.

We offer **customizable** solutions to create convenient space to meet your requirements.







Service Point

Consumer habits are focused on a more quality-based approach, influenced by the development of in-store services and advice. Payment techniques are changing and stores are increasingly part of a lifestyle, where **service points** must be accessible and efficient.

Please let us know your requirements and our project teams will work out the perfect solution at your side.

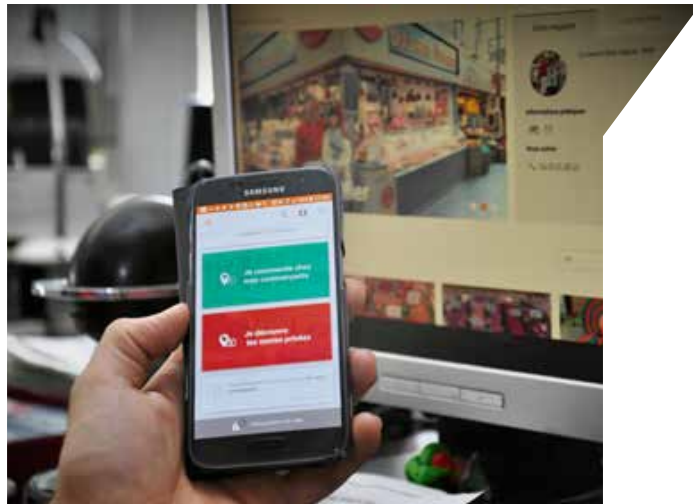
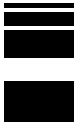





Caddie.Transtock H. 1040 / 1850mm



LARGE VERSION

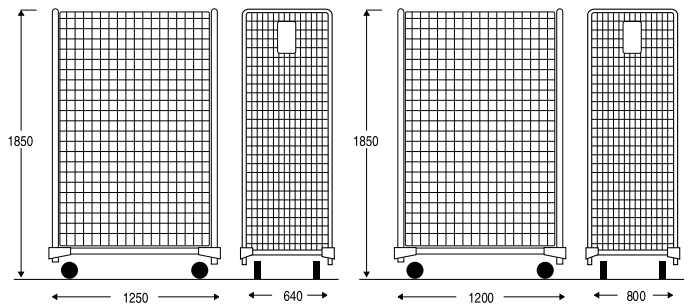

Ref.: 4 437 85

Ref.: 4 437 80

MEDIUM VERSION

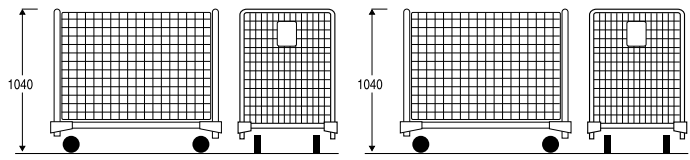

Ref.: 4 437 02

Ref.: 4 437 06

A solution for a safer and smoother logistics. Very easy to handle in narrow alleyways and recommended for internal handling.



Caddie.Drive

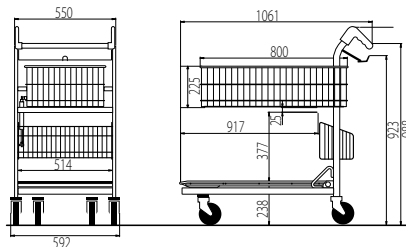

Ref. 4 490 05 03

Nesting : 300 mm

10 nested trolleys: 3761 mm



TransCaddie 3 shelves

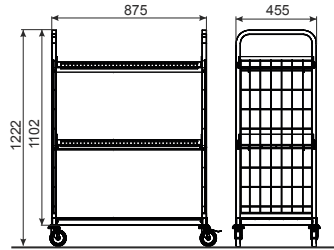

Ref. 4 444 61 03

TransCaddie L

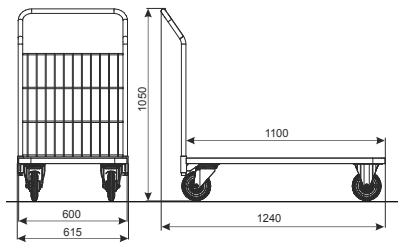

Ref. 4 430 10 03

Permitted load: 400 kg

Caddie.Ergoload M

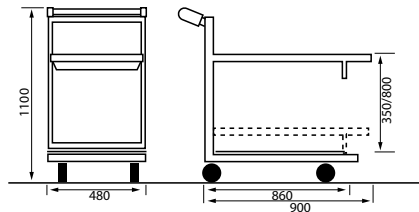

Nesting distance: 300 mm

Ref. 6 600 35 03



Guiding

The versatility of **CADDIE®** Control products means that there is a solution for every situation and every store layout. Whether it's for large supermarkets, small or local convenience stores or boutiques, there is always a solution to match your needs.

More than just products, **CADDIE®** offers you solutions that are a marketplace benchmark.

We aim to offer high quality access control and guidance systems suited to every environment and every budget.

Our extensive range will meet your specific needs: electrical or mechanical gates, customer guidance barriers, walls, partitions or security systems.



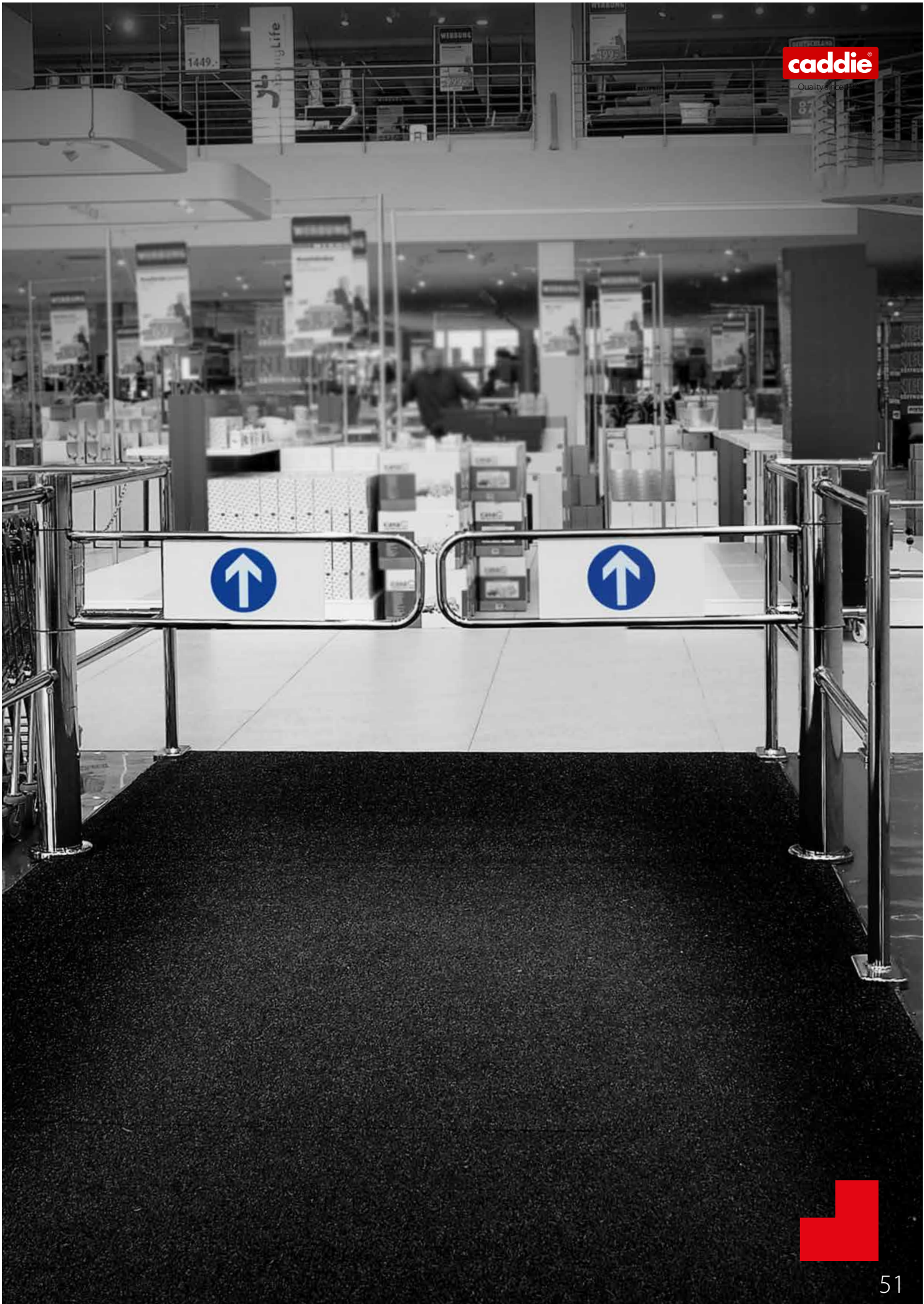



Download new catalogs







Les Ateliers Réunis Caddie® S.A.S
1, route de Herrlisheim
67410 Drusenheim
FRANCE
Tel. : +33 (0)3 88 90 62 62
Fax : +33 (0)3 88 90 62 00
www.caddie.com



Customized Solutions

caddie®

Quality since 1928