

by
PCM
HABILCLASS

MEDI.CADDIE®

STERILISATION
FILES FLOW
HOSPITAL LOGISTICS
FRONT OFFICE



PATIENTS FILES

TRANSPORT

STERILISATION

PACKING

WORK SURFACES AND TABLES	06
PACKAGING ACCESSORIES	07
TRAYS AND BASKETS	08-09

DISTRIBUTION

SHUTTLE CABINETS AND BINS	10
SHUTTLE SYSTEM	11

STORAGE

WALL STORAGE	12
FIXED STOCKAGE	13
MOBILE STORAGE AND ACCESSORIES	14-17
STORAGE ACCESSORIES	18-19

OPERATING THEATRE

STERICADDIE TROLLEYS AND ACCESSORIES	20-26
CHANGING ROOM EQUIPMENT	27
DECONTAMINATION BINS	28-30
LOGISTIC UNIT	31

FILES FLOW

TRANSPORT

SECURITY TROLLEY AND ACCESSORIES	34-38
OPEN TROLLEY AND ACCESSORIES	39-43

COMPUTER TROLLEY

PC TROLLEY	44-45
------------	-------

STORAGE

STORAGE FURNITURE	46-47
-------------------	-------

SHELVING

SHELVING FURNITURE	48-50
--------------------	-------

ADMINISTRATIVE FILES

HANDCART TROLLEY	51
FILES TROLLEY	52

RANK

CLASSIFICATION SYSTEM	53-55
-----------------------	-------

HOSPITAL LOGISTICS

SUPPLY

TRANSPORT TROLLEYS	58-59
COLLECTION TROLLEY	60-61

FRONT OFFICE

GUIDE

GUIDE SYSTEMS	64
---------------	----

INFORMATION

INFORMATION BOARD	65
EXHIBITIONS SCREEN	65

GLOSSARY

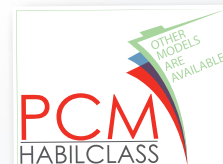
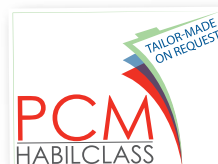

Tailored product on request Other models are available



Discover the Medi.Caddie by



Fifty years of know-how serving quality !



MEDI.CADDIE®, SUPERIOR QUALITY BRAND WORTHY OF TRUST

The full Caddie guarantee bases the superiority of its trolleys on the total control of the value chain:

Design standards

Design standards are applied to guarantee the quality of **Caddie**® trolleys in terms of strength, ergonomics and safety in use.

Caddie® has used new technologies for its new Hybrid trolley. These call on performance criteria that extend beyond the trade's design standards. **Caddie**® is targeting sustainable customer satisfaction even for the new steel composite functionalities.

Production Process

The wire technique, know-how that built up the **Caddie**® reputation, is based on automated production processes designed especially by our teams and proven in the motor industry.

Our quality management system complies with the international standard ISO 9001 which, combined with the production process repeatability, maintains a constant level of **Caddie**® quality for all our customers.

Quality control

Production compliance is assessed by passing each unit through a test bench before shipment: Tests of mechanical strength, ergonomics, handling and safety criteria to ensure that customer needs are met along with the significant **Caddie**® quality requirement.

This guaranteed traceability throughout the life cycle means total control of all trolleys in service and monitoring of maintenance operations.



Sharing the Caddie legend

Founded in 1928, **Caddie**® is a worldwide well-known family company established in Drusenheim, Alsace.

Historical partner of international retail, **Caddie**® is the French brand of reference. We offer quality equipment for retail and logistics.

The major retail trade has changed constantly in fifty years. At the same time, **Caddie**® has demonstrated its ability for constant change through greater personalisation of the products on offer based on observing users and the consumption experience.

From design to manufacturing, our experienced teams rely on 50 years of know-how to create the worldwide standards of equipment.

Our expertise is also to support our customers by deploying innovative customized solutions for each business line.

This exceptional approach helps to perpetuate the legend and confirm **Caddie**® status as a leading international partner of major retail outlets.



Advertising poster Ateliers Réunis - 1960



Advertising poster Caddie by Les Ateliers Réunis - 2015

The user is at the heart of the **Caddie**® thought.

Under this approach, the needs, new expectations and consumer-specific characteristics are taken into account at each stage in the **Caddie**® product development process. We create value at the act of purchasing through well-thought-through self-service solutions to support consumer purchasing behaviour and convey positive values of quality and human consideration, in the stores.

The performance objective shared throughout the world **Caddie**® has always provided solutions to expand your sales and convey the values and image of your store, with the focus on building customer loyalty. **Caddie**® incorporates purchasing habits and the specific features of every world market so that it can offer equipment suitable for your needs that gives you entire satisfaction.



Quality since 1928

MEDI.CADDIE® - STERILISATION

A complete solution at each step of the sterilisation process.

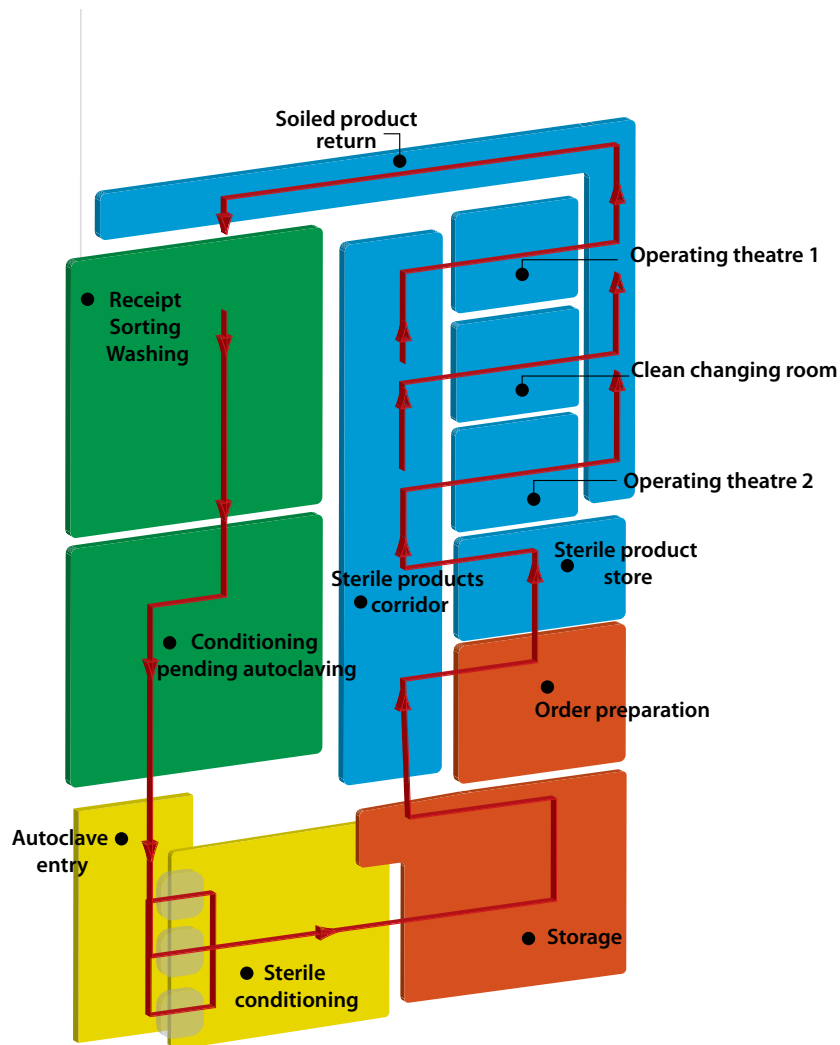

The implementation of a sterilisation circuit requires the strict application of asepsis rules and of both efficient and ergonomic working conditions. This implies rational facility layout, well-designed product and instrumentation routes, with as few load breaks as possible and permanent isolation of the various areas.

STERILISATION

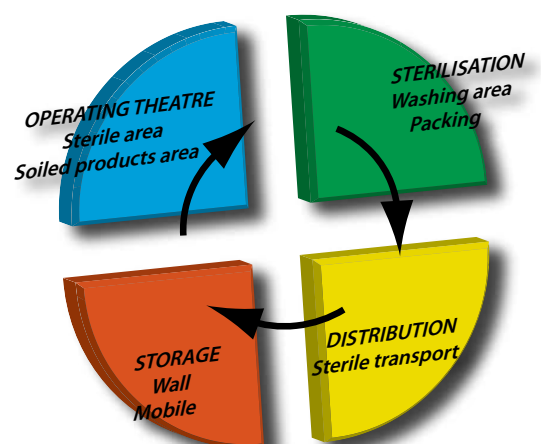

CADDIE PLAN PACKING TABLE

Frame made from 18/10 stainless steel square tubular posts. 18/10 brushed stainless steel tabletop to avoid light reflection, with flanged edges to avoid injury. Excellent resistance to chemicals. 4 Ø 125 mm Nylox casters (2 fitted with brakes) with stainless steel ball bearings, solid rubber tyres and plastic hubs.



- > **Conditioning table W.1500**
ref. 2 203 59 18
+ 2 203 48 18 (upper grill)
+ 2 203 22 18 (lower grill)

Caddie Plan table		Depth 750 Height 900
Length	Tabletop	Reference
1250 mm	Stainless steel	2 203 51 18
1500 mm	Stainless steel	2 203 59 18

BACKING FRAMES

18/10 stainless steel. CADDIE PLAN workbenches and tables can be fitted with a single-sided backing frame that can in turn be fitted with 4 to 6 accessories.



- > **StéricADDIE TROLLEY**
ref. 2 220 43 50
+ accessories
- > **Backing frame L1500**
ref. 2 203 27 18
+ accessories

Backing frame			
Length	Reference	Accessories	Weight
1250 mm	2 203 25 18	4	10
1500 mm	2 203 27 18	4	11

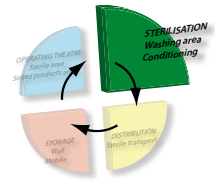

CADDIE PLAN CONDITIONING ACCESSORIES

Caddie Plan accessories



> **Lower grill**
ref. 2 203 21 18



> **Backing frame**
ref. 2 203 25 18



> **Roll dispenser**
ref. 2 258 25 18

LOWER & UPPER GRILL

Constitutes an add-on storage area for bins, baskets, sheets. 18/10 stainless steel. Mesh size: 100 x 200 mm.

Grills for packing tables and workstations		
Length	Lower	Upper
1250 x 300 mm	2 203 21 18	2 203 46 18
1500 x 300 mm	2 203 22 18	2 203 48 18



> **Vertical support**
ref. 2 258 20 18

Packing accessories



> **Vertical support**
ref. 2 258 20 18
For sterilisation sheets and pouches. 18/10 stainless steel. W560 x H305 mm



> **Multiservice shelf**
ref. 2 258 03 18
For small objects and sterilisation pouches. 18/10 stainless steel. Effective area: 550 x 246 mm



> **10-bin support**
ref. 2 258 21 18
18/10 stainless steel.

> **1L grab bins**
ref. 2 258 51 54
Blue polypropylene



> **UTS basket 6.3.1,5**
ref. 2 256 21 18
Overall dim.: 600x400x150



> **2-shelf support**
ref. 2 258 22 18
Appreciated for its versatility. 18/10 stainless steel. Eff. dimensions of a shelf: 530 x 165 mm



> **Sheath roll dispenser**
ref. 2 258 25 18
For rolls with a max Ø of: 180 mm. 18/10 stainless steel.



> **4-bin support**
ref. 2 258 24 18
18/10 stainless steel.

> **4L grab bins**
ref. 2 258 54 54
Blue polypropylene



> **UTS basket 6.4.3**
ref. 2 256 32 18
Overall dim.: 600x400x300

INSTRUMENT TRAY





STERILISATION - PACKING

STERICADDIE INSTRUMENT TRAYS STERICADDIE

Models compliant with AFNOR regulation S90.322 and the DIN 58952 standard. They have rounded corners, handles that fold to fit completely within the tray.



- > **STERICADDIE instrument trays STERICADDIE**
- Excellent transparency: good circulation of sterilising agent.
 - Folding handles: good tray grip.
 - Fine mesh (4.5 x 4.5 mm): strength.
 - Electropolishing and carefully machined finish: avoids any risks of paper tearing.
 - Compatible with other sterilisation systems.

Instrument TRAY	Overall dim. in mm	Reference	Usable inner dim. In mm	Conditions of use
	245 x 175 x H 50	2 224 15 18	240 x 165 x H 40	<ul style="list-style-type: none"> • Paediatric, facial, eye, hand and foot surgery. • Tracheotomy, catheter delivery. Denudation, pulpectomy. Thin and short instruments (± 140 mm).
	245 x 350 x H 80	2 224 38 18	240 x 340 x H 65	<ul style="list-style-type: none"> • Autostatic retractor, valves, vascular clamps, forceps.
AFNOR DIN 	250 x 485 x H 50	2 224 45 18	240 x 480 x H 40	<ul style="list-style-type: none"> • Curettage, cholecystectomy, osteosynthesis (long bone) Instruments of all sizes. • Autostatic retractor, valves, vascular clamps, forceps, endoscopy.
	250 x 485 x H 130	2 224 48 18	245 x 480 x H 115	<ul style="list-style-type: none"> • Orthopaedics. • Laparotomy, gastrectomy, nephrectomy, oophorectomy. Instruments of all sizes.

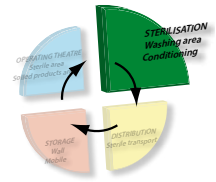

STERICADDIE UTS BASKETS W.600

18/10 stainless steel

Corrosion-resistant, able to withstand the most aggressive disinfectants. Hygienic, aseptic, easy to clean.

- Robust construction: durability.
- Electro polished flawless finish: no paper tearing.
- High-cut handles: easy handling.
- Identification plate: visual inspection.
- Standardised: can be used in all types of autoclave.
- Uniform base structure to limit formation of condensation
- Stackable. Ease of storage. Space saving

Cut out front panel: products are easier to grasp.

The standardised length of 600mm ensures the basket's modularity with the various trolleys and supports.

Compliant with AFNOR regulation S.90.322 and with the DIN 58952 standard. CE marking: all of our sterilisation baskets conform to the essential safety requirements of European directive 93/42/EC.



> UTS basket 6.3.3
ref. 2 256 22 18



> Widthwise divider

> Lengthwise divider

BASKET 1/1	Overall dim. in mm Internal dim. In mm	Weight Capacity
6.1.5.1.5 2 256 20 18	600 x 150 x H 150 585 x 135 x H 135	1.5 kg 11 dm ³
6.3.1.5 2 256 21 18	600 x 300 x H 150 585 x 280 x H 135	3 kg 22 dm ³
6.3.1.5 high-cut 2 256 28 18	600 x 300 x H 150 585 x 280 x H 130	2.8 kg 22 dm ³
6.3.3 2 256 22 18	600 x 300 x H 300 585 x 280 x H 280	3.8 kg 45 dm ³
6.3.3 high-cut 2 256 29 18	600 x 300 x H 300 585 x 280 x H 280	3.7 kg 45 dm ³
6.4.1.5 2 256 31 18	600 x 400 x H 150 585 x 385 x H 135	3.6 kg 30 dm ³
6.4.1.5 high-cut 2 256 38 18	600 x 400 x H 150 585 x 385 x H 130	3.4 kg 30 dm ³
6.4.3 2 256 32 18	600 x 400 x H 300 585 x 385 x H 280	4.5 kg 63 dm ³
6.4.3 high-cut 2 256 39 18	600 x 400 x H 300 585 x 385 x H 280	4.4 kg 63 dm ³

1/2 module BASKET	Overall dim. in mm Internal dim. In mm	Weight Capacity
3.4.1.5 2 256 34 18	300 x 400 x H 150 285 x 385 x H 130	2.3 kg 15 dm ³
3.4.3 2 256 33 18	300 x 400 x H 300 285 x 385 x H 280	2.9 kg 30 dm ³



> Half-module
UTS basket 3.4.3
ref. 2 256 33 18



> High-cut
UTS basket 6.3.3
ref. 2 256 29 18



> Stainless steel
label-holder
ref. 2 256 11 18
set of 10.
40 x 90 mm.

DIVIDER Reference	Height in mm	Compatible with UTS baskets
W.300 Widthwise Divider 2 256 51 18	150	2 256 21 18 2 256 22 18 2 256 29 18
W.300 Widthwise separation 2 256 52 18	300	2 256 22 18 2 256 29 18
W.400 Widthwise separation 2 256 61 18	150	2 256 31 18 2 256 32 18 2 256 39 18
W.400 Widthwise separation 2 256 62 18	300	2 256 32 18 2 256 39 18
W.600 Lengthwise separation 2 256 55 18	150	All L600 basket models

STERILISATION - DISTRIBUTION

SHUTTLE CABINETS FOR CONTAINERS, BINS AND BASKETS

Offering maximum safety and mobility, these cabinets can be used to distribute all sterile products under perfect conditions of hygiene.
A genuine link between the central sterilisation unit and the operating theatre.



> **4-level Shuttle cabinet**
ref 2 290 22 11 (+ accessories)



> **Shuttle cabinet for disinfection bin transport**
ref 2 290 49 11 (+ accessories)



> **Shuttle cabinet**
Made from anodized aluminium (10 microns).
Anti distortion, reinforced base frame
2 completely foldaway doors, with magnetic system to hold the door open Fitted with a lock and provided with a set of keys.
Grey rubber bumper.

Accessories (optional)

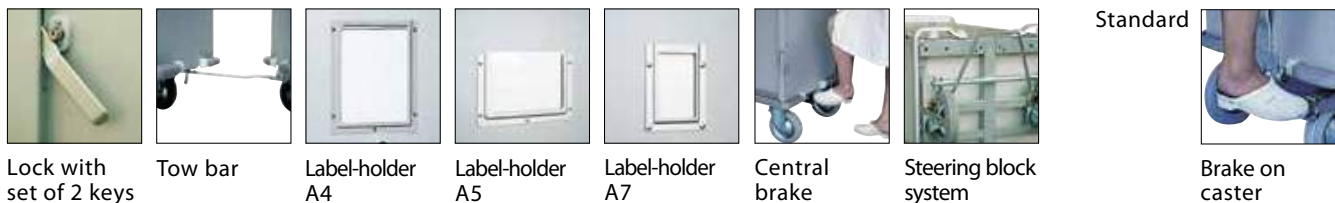

Shuttle cabinet		Reference	Overall dim. in mm	Inner dim. of each level	Casters ø in mm	Fixed wheels(F) Casters (P)	Weight in kg	Load in kg	Max. capacity in 6.3.3 and 6.4.3 baskets
Sterile product distribution	H.1800 4 levels	2 290 22 11	1400x720 xH.1750	1300x630xH.320	200	2F + 2S	75	300	16 / 12
Bin transport	H.1200 2 levels	2 290 49 11	1235x630 xH.1205	1075x540xH.420	160	2F + 2S including 1 with brake	57	150	2 x 6 bins

MEDICADDIE AND TRANSPORT BINS



> **Bins 60L. H.300 mm**
ref. 2 259 51 55 55
with cover and handle
Dim. hors tout en mm :
600 x400 xH.338



> **22L transport bin**
600 x 400 x H.145 mm
ref. 9 980 40 50
Stackable.
Can be secured to StériCaddie trolley



> **Super Service trolley**
ref. 4 461 85 45
(without bins)



> **Plastic mobile base**
ref. 4 498 73 53
(Without basket)

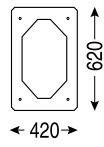

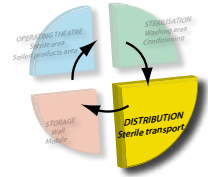

SHUTTLE SYSTEM

The development of the SHUTTLE system results from the outsourcing and pooling of sterilisation services. The shuttle and transport trolley assembly is used to distribute sterile products and for collecting products to sterilise:

- transport of sterile equipment from the central sterilisation unit to the operating theatre and other hospital departments,
- recovery of equipment to sterilise after use in the operating theatre and other hospital departments.

SHUTTLE is the ideal solution for guaranteeing the protection of sterile products during outdoor transport. The SHUTTLE system is supplemented by an unloading platform in the storage areas, which saves time and offers greater efficiency and manoeuvrability .



> **Special Shuttle cabinet**



> **1 Shuttle transport trolley**



> **Shuttle storage platform**



> **1 section shuttle ISO**
600 x 400 x 300 or
DIN 600 x 300 x 300



> **3 section Shuttle DIN**
600 x 300 x 300



> **1 section Shuttle DIN**
600 x 300 x 300

WALL STORAGE

STERILISATION - STORAGE

WALL SUPPORTS

Receives all types of basket. Rapid visual inspection of contents. Facilitates room hygiene as no floor space used.



> **Wall supports**
Easy maintenance thanks to spacers guaranteeing accessibility for cleaning.

MULTIHOOK range
Space between levels: 215 mm to hold 130 mm high baskets and accessories. These mounts significantly increase the effective storage volume.
18/10 stainless steel
Square tube: 25 x 25 mm.

EPOXY VERSION AVAILABLE



TYPE	Reference each	Capacity in number of baskets	Weight in kg	Space between hooks
W.350	2 221 40 18	1	0.3	-
W.900	2 221 48 18	4	0.75	215
W.1300	2 221 52 18	6	1.1	215
W.1600	2 221 56 18	7	1.3	215
W.1900	2 221 50 18	5	2.2	415

> Fitting advice

Recommended distance between supports (hook to hook): 530 mm. The spacers distance the mounts from the wall, thus facilitating their cleaning. Leave a "hygienic" distance of no less than 150mm above the floor level.

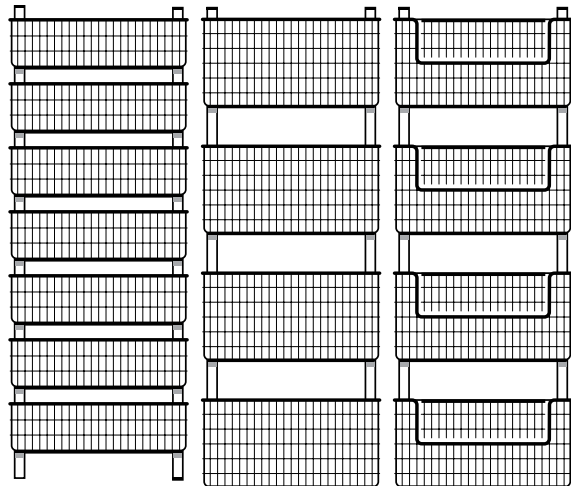

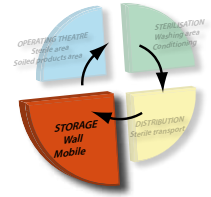

SHELVING UNITS

Multiple size combinations possible.
Used for storage and transport of packed and sterile equipment.



> **Static shelving**
H.1700 and H.2200

> **To each space its own dimensions**

3 upright heights: 1000, 1700 and 2200 mm
3 shelf lengths: 700, 1000 and 1300 mm
2 shelf and upright depths: 500 and 600 mm.
Posts on casters are available in 1150 and 1865 mm heights.

> **Galvanized**

Steel, white Arpoxy or 18/10 stainless steel shelving.
Complete modular system compliant with hygiene requirements.

- 18/10 stainless steel.
- Steel tube: 25 x 25 mm.
- Level adjustable in 125 mm increments.
- Telescopic frames or removable metal plate shelves.
- Available in 2 heights: H.1150 and H.1865 mm.
- Avoids load breaks between sterile stocks and wards.
- Will accept both containers and baskets, standardised 6 x 3 x 3 or 6 x 3 x 1.5.
- ø 125 mm Nylox casters (including 2 with brakes).



> **Mobile shelving H.1700**

WALL STORAGE

STERILISATION - STORAGE

STATIC MULTICADDIE

Complete and robust fixed modular system compliant with hygiene standards. Disinfectable, mobile: high degree of hygiene and asepsis. Multiple size combinations. Used to store conditioned and sterile equipment.

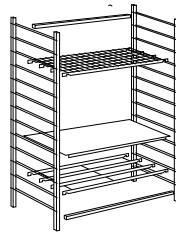

Type	500 x 700	500 x 1000	500 x 1300	600 x 700	600 x 1000	600 x 1300
Usable dimensions in mm	445x670	445x970	445x1270	545x670	545x970	545x1270

Standard unit

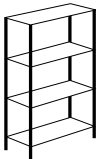

Consisting of:
1 post.

(H1700) 4 wire shelves - (H2200) 5 wire shelves. 2 connecting pieces If a base element is used alone, we recommend fitting 2 additional connecting pieces.

	750	1050	1350	750	1050	1350
Height 1700	510 9 986 14 18/50	510 9 986 34 18/50	510 9 986 37 18/50	610 9 986 74 18/50	610 9 986 94 18/50	610 9 987 14 18/50
Height 2200	510 9 986 24 18/50	510 9 986 44 18/50	510 9 986 47 18/50	610 9 986 84 18/50	610 9 987 04 18/50	610 9 987 24 18/50

In-line extension unit

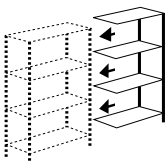

Consisting of:
1 post.

(H1700) 4 wire shelves - (H2200) 5 wire shelves. 2 connecting pieces Fits onto a base or extension element (in-line or corner) of same depth.

	710	1010	1310	710	1010	1310
Height 1700	510 9 986 15 18/50	510 9 986 35 18/50	510 9 986 38 18/50	610 9 986 75 18/50	610 9 986 95 18/50	610 9 987 15 18/50
Height 2200	510 9 986 25 18/50	510 9 986 45 18/50	510 9 986 48 18/50	610 9 986 85 18/50	610 9 987 05 18/50	610 9 987 25 18/50

Corner extension unit

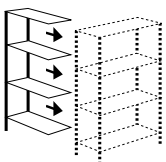

Consisting of:
1 post.

(H1700) 4 wire shelves - (H2200) 5 wire shelves. 2 connecting pieces Fits onto a base or extension element (in-line or corner).

	710	1010	1310	710	1010	1310
Height 1700	510 9 986 16 18/50	510 9 986 36 18/50	510 9 986 39 18/50	610 9 986 76 18/50	610 9 986 96 18/50	610 9 987 16 18/50
Height 2200	510 9 986 26 18/50	510 9 986 46 18/50	510 9 986 49 18/50	610 9 986 86 18/50	610 9 987 06 18/50	610 9 987 26 18/50

To order, match the last 2 digits of the references in the table with the desired item finis

18 18/10 stainless steel
50 White Epoxy coating

For all static loads make request.

STERILISATION

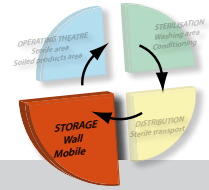

Wire shelving

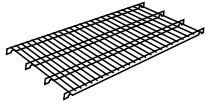

TYPE (depth x length)	500 x 700	500 x 1000	500 x 1300	600 x 700	600 x 1000	600 x 1300
Usable dimensions in mm	445 x 670	445 x 970	445 x 1270	545 x 670	545 x 970	545 x 1270
Epoxy	9 985 70 50	9 985 71 50	9 985 81 50	9 985 77 50	9 985 80 50	9 985 83 50
18/10 stainless steel	9 985 70 18	9 985 71 18	9 985 81 18	9 985 77 18	9 985 80 18	9 985 83 18
Weight	3 kg	4 kg	4,5 kg	3,3 kg	4,5 kg	6,7 kg

Plate metal shelves

Used alone or with support frames, depending on load

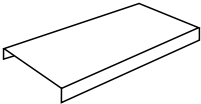

TYPE (depth x length)	500 x 700	500 x 1000	500 x 1300	600 x 700	600 x 1000	600 x 1300
Usable dimensions in mm	445 x 670	445 x 970	445 x 1270	545 x 670	545 x 970	545 x 1270
Epoxy	9 985 48 50	9 985 52 50	9 985 56 50	9 985 58 50	9 985 62 50	9 985 64 50
18/10 stainless steel	9 985 48 18	9 985 52 18	9 985 56 18	9 985 58 18	9 985 62 18	9 985 64 18
Weight	2,7 kg	4,1 kg	4,5 kg	3,2 kg	4,7 kg	6 kg

Self-supporting plate shelves Permissible load: 120 kg

These shelves do not require a support frame.

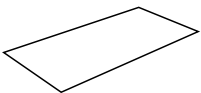

TYPE (depth x length)	500 x 700	500 x 1000	500 x 1300	600 x 700	600 x 1000	600 x 1300
Usable dimensions in mm	445 x 670	445 x 970	445 x 1270	545 x 670	545 x 970	545 x 1270
Epoxy	9 985 49 50	9 985 53 50	9 985 54 50	9 985 65 50	9 985 66 50	9 985 67 50
18/10 stainless steel	9 985 49 18	9 985 53 18	9 985 54 18	9 985 65 18	9 985 66 18	9 985 67 18
Weight	5 kg	6,9 kg	8,8 kg	5,9 kg	8,1 kg	10,4 kg

Posts Depth 500	Height	1700	2200	2200
	Number of levels	7	13	17
	Epoxy	9 985 05 50	9 985 15 50	9 985 25 50
	18/10 stainless steel	9 985 05 18	9 985 15 18	9 985 25 18
	Weight	3,7kg	6,6 kg	8,6 kg

Posts Depth 600	Height	1000	1700	2200
	Number of levels	7	13	17
	Epoxy	9 985 06 50	9 985 16 50	9 985 26 50
	18/10 stainless steel	9 985 06 18	9 985 16 18	9 985 26 18
	Weight	4,2kg	7,4 kg	9,5 kg

Connecting bars



Type	700	1000	1300
Dimensions	680 mm	980 mm	1280 mm
Epoxy	9 985 87 50	9 985 90 50	9 985 93 50
18/10 stainless steel	9 985 87 18	9 985 90 18	9 985 93 18
Weight	0,7 kg	0,9 kg	1,2 kg

STERILISATION - STORAGE

MOBILE MULTICADDIE

Complete and robust mobile modular system compliant with hygiene standards.

The structure of our MULTICADDIE trolleys is identical to that of the MULTICADDIE MOBILE SHELVING.

They are fitted with four Ø 125 mm silent rubber casters with soft solid tyres, 2 of which can be fitted with brakes

These transfer trolleys are suitable for transporting standardised 600 x 300 mm sterile elements.

- 18/10 stainless steel.
- Steel tube: 25 x 25 mm.
- Level adjustment in 125 mm increments.
- Telescopic frames or removable metal plate shelves.
- Available in 2 heights: H.1150 and H.1865 mm.
- Avoids load breaks between sterile stocks and wards.
- Will accept both containers and baskets, standardised 6 x 3 x 3 or 6 x 3 x 1.5.
- Ø 125 mm Nylox casters (including 2 with brakes).

As standard:

MULTICADDIE H.1150 trolleys are fitted with 3 storage levels.

MULTICADDIE H.1865 trolleys are fitted with 4 storage levels.

They are compatible with the MULTICADDIE shelving system.

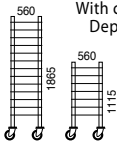
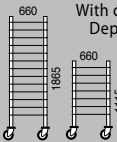
Uprights	Height	1865
 With casters. Depth 500	Number of levels	13
	18/10 stainless steel	9985 17 18
	White Epoxy	9985 17 50
 With casters. Depth 600	Number of levels	13
	White Epoxy	9985 18 50
	18/10 stainless steel	9985 18 18
	Weight	9.2 kg



> Multi trolley H.1865

STERILISATION

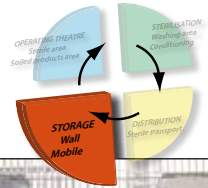

SHELVING ACCESSORIES

STERILISATION - STORAGE

MULTICADDIE ACCESSORIES

Sheet metal shelf



> **Sheet metal shelf**
ref 2 220 19 18

Garment rail



Hanger bar	Epoxy	Inox
length. 700	9 985 37 50	9 985 37 18
length. 1000	9 985 40 50	9 985 40 18
length. 1300	9 985 43 50	9 985 43 18



Telescopic frame



> **Telescopic frame**
ref 2 220 16 18

Trolley cover

> **Trolley cover with zipper**
ref 9 985 13 50
1000 x 500 x 1850



Rear retaining grill



> **Rear retaining grill**
Prevents objects from falling backward, can be fitted onto wire or plate shelves.
Galvanized steel + clear varnish.

Holding screen	Epoxy	Inox
length. 700	9 985 94 50	9 985 94 18
length. 1000	9 985 95 50	9 985 95 18
length. 1300	9 985 96 50	9 985 96 18

Height adjustable leveller (set of 2) Divider



> **Height adjustable leveller (set of 2)**
ref 9 985 99 01
Can be placed under both legs of a post to compensate for floor irregularities.

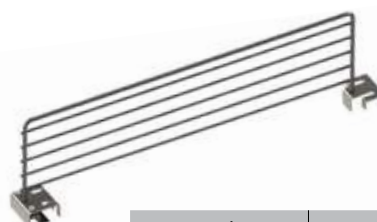

> **Divider**
Used to compartmentalise a plate or wire shelf.
Height 150 mm.
Easy to remove.

Divider	Epoxy	Inox
length. 500	9 985 85 50	9 985 85 18
length. 600	9 985 86 50	9 985 86 18

STERILISATION

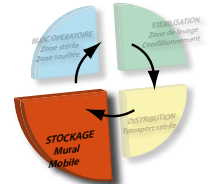

Corner joints (set of 2)

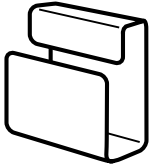

- > **Corner joints (set of 2)**
ref 9 985 97 18
For sheet metal shelves.

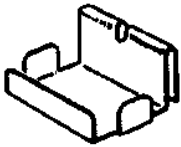

- > **Corner joints (set of 2)**
ref 9 985 98 18
Used when adding a corner extension, they provide full access to the angle, perfect and a level gap free junction.



Medical probes transporter trolley



- > **Medical probes transporter trolley**
ref. 9 986 02 18
Storage of SONDES boxes in vertical position and sorted by size. Reference marking is immediately visible and can be read on the top side.
Dimensions : 1000 x 600 x 1100 mm.
Stainless steel.
2 shelves adjustable in height.
Label holder as an option ref. 2 256 11 18.

STERICADDIE TROLLEYS

The complete specialist system, including trolleys, baskets, accessories and wall supports, designed for use with operating theatre equipment. Ergonomic constraints, and more specifically the considerable progress made in the field of asepsis, imply a new manner of viewing the operating theatre.



STERILISATION

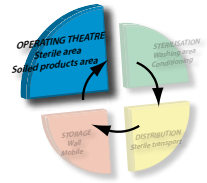

STERICADDIE SPECIAL CONTAINER TROLLEY

To ensure the operating theatre is thoroughly cleaned and disinfected, it must be possible to remove as much of the equipment as possible. No more built-in equipment. CADDIE offers various specialist theatre, supply and soiled material removal trolleys that meet this requirement perfectly.



> STERI Special Container TROLLEY

(without accessories)
ref 2 220 87 18
18/10 stainless steel.
Single-piece structure.
14 positioning levels

ACCESSORIES:

> **Telescopic frame**
ref 2 220 16 18
18/10 stainless steel.
Permissible load: 25 kg.
Comprised of a support frame
and a sliding shelf.

> **Sheet metal shelf**
ref 2 220 19 18
18/10 stainless steel.
Permissible load: 25 kg.
High-quality electropolished
surface finish.

STERICADDIE special container trolleys possess 14 positioning levels.
Space between levels: 100 mm.
Minimum effective space: 87 mm.
Many possible combinations for a single trolley.

> Characteristics:

- 18/10 stainless steel.
- Single-piece structure
- Base made from steel tube, cross-section 20 x 40 mm.
- Double-sided with space for standardised containers and baskets: 6 x 3 x 3 or 6 x 3 x 1.5.
- Avoids load breaks between sterile product stocks and wards.
- Height adjustment in 100 mm increments.
- 4 hook levels per side.
- ø 125 mm Nylox casters (including 2 with brakes).

STERICADDIE trolleys are compatible with the MULTICADDIE shelving system.



> **Basic Steri trolley**
ref. 2 220 87 18



> **Steri trolley with 4 telescopic frames**
ref. 2 222 10 18



> **Additional plate shelf**
ref. 2 220 19 18



> **Additional telescopic frames**
ref. 2 220 16 18

STERILISATION - OPERATING THEATRE

SINGLE AND DOUBLE_SIDED STERICADDIE TROLLEYS

Highly versatile trolleys, perfectly suited to carrying StériCaddie baskets and accessories into the operating theatre.



> **Steri trolley H.1500**
ref 2 220 13 18 (+ accessories)
18/10 stainless steel.

Height	Type	Levels	Casters		Capacity in number of baskets	Overall dim. in mm	Space between levels	Weight in kg
			Anti-static rubber	Nylox				
H.1500	double-sided	3	2 220 52 18		6	630 x 840 x H.1520	420	11.6
	single-sided	4	2 220 61 18	2 220 10 18	4	630 x 515 x H.1520	315	11
	double-sided		2 220 62 18	2 220 13 18	8	630 x 840 x H.1520		10.6
H.1100	double-sided	3	2 220 54 18	2 220 05 18	6	630 x 840 x H.1100	280	11

* Accessories must be ordered separately

STERILISATION

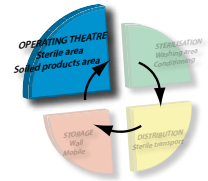

STERICADDIE MOBILE SOLUTION WITH ADAPTED CASTER SYSTEM

Model presented consisting of:
Single-sided Stéri trolley, 4 levels of 4 x 6.3.3 baskets, 8 dividers and 8 incline supports.



**EPOXY
VERSION
AVAILABLE**

> **Steri trolley H.1500**
ref 2 220 10 18 (+ accessories)



- > **Ant-static rubber caster**
ref 1 160 94 56
ø 125 mm
- > **Ant-static rubber caster with brake**
ref 1 160 95 56
ø 125 mm



- > **NYLOX caster**
ref 1 163 43 55
ø 125 mm
(LERPAC certified)
- > **NYLOX caster with brake**
ref 1 163 41 55
ø 125 mm
(LERPAC certified)

STERILISATION - OPERATING THEATRE

SINGLE AND DOUBLE-SIDED STERICADDIE TROLLEYS



Half module UTS basket



> **Half-module UTS basket 3.4.3**
ref. 2 256 33 18

Open support shelf



> **Open support shelf**
ref 2 258 06 18
For catheters and containers.
18/10 stainless steel.
Bottom mesh: 21 x 30 mm, sides: 21 x 22 mm

Basket incline support

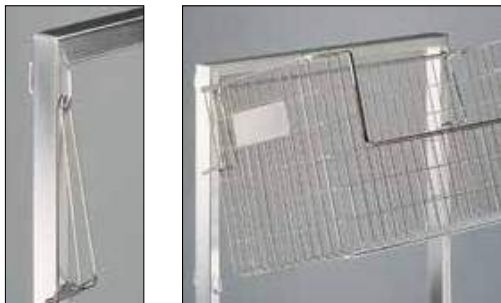

> **Basket incline support**
ref 2 258 23 18
18/10 stainless steel.
Used to tilt the baskets.

Support 8 hooks



> **Support 8 x 180mm hooks**
ref 2 258 07 18
For catheters in soft packaging.
Allows sorting by size and by date brought into service.
Fits onto Stéri trolleys and wall mounts, along with on the sides or from of UTS baskets. 18/10 stainless steel.
Overall dim.: 565 x 195 x H.80 mm. Weight: 0.7 kg.

Reversible console



> **Reversible console**
18/10 stainless steel
ref 2 258 14 18

Catheter probe rack



> **Catheter /probe rack**
ref 2 258 16 18
For storing and dispensing catheters, probes etc.
18/10 stainless steel.
Overall dimensions:
345 x 130 x H.400 mm.
3 compartments.
Empty weight: 0,8 kg.
Permissible load: 5 kg.

STERILISATION

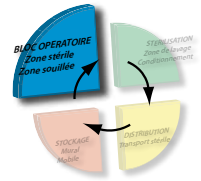

2 Level shelf



- > **2-level shelf**
ref 2 258 12 18
Fits onto trolleys and wall supports.
Specially designed for the operating theatre.
Holds 10 standard ligature boxes.

4 Level shelf



- > **4-level shelf**
ref 2 258 13 18
Holds 20 standard ligature boxes.

Multi Service shelf



- > **Multi-Service shelf**
ref 2 258 22 18
Allows, amongst other things, the storage and presentation of pharmaceutical items: cotton wool, dressings, disinfectant, haemostatic products, etc.
18/10 stainless steel. Overall dim.: 575 x 280 x H.260 mm.
Mesh: 23 x 43 mm.

Stericaddie Support



- > **STERICADDIE SUPPORT**
mount ref 2 258 03 18
Two trays for grab bins.
Fits onto SteriCADDIE trolley or wall mount.
Capacity: 5 x 1 litre bins per level.
18/10 stainless steel.
Overall dimensions: 560 x 200 x H.305 mm.

Space doubling adapters



- > **Space doubling adapters**
ref 2 258 18 18 (set of 2)
18/10 stainless steel. Used to create an extra effective space of 155 mm between accessories.

MOBILE TECHNICAL UNITS AND ACCESSORIES



18/10 stainless steel racks

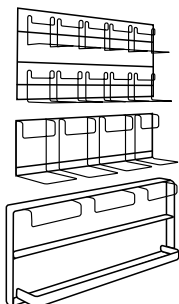

- > **Holder for 10 x 1L bins**
ref 2 258 21 18
- > **Holder for 4 x 4L bins**
ref 2 258 24 18
- > **Holder for 3 x 13L bins**
ref 2 258 33 18

Grab bins



- > **1-litre bin**
ref 2 258 51 54
- > **4-litre bin**
ref 2 258 54 54
- > **13-litre bin**
ref 2 258 58 53

Polyethylene grab bin			Overall dim. in mm
1L	red	2 258 51 53	
	blue	2 258 51 54	
4L	red	2 258 54 53	240x150x H.125
	blue	2 258 54 54	
13 L	red	2 258 58 53	360x215x H.195
	blue	2 258 58 54	



Plastic bin



- > **Plastic bin**
ref 7 760 00 53
Overall dim.:
295x100xH.100 mm
Red Acrodur

Reversible console



- > **Reversible console. 18/10 stainless steel**
ref 2 258 14 18
Ideal for carrying and presenting electronic instruments, monitors, etc. Effective tray dim.: 560 x 365 mm. Permissible load: 25 kg.

Glove racks



- > **Glove racks**
ref 2 258 15 18
Capacity: approximately 60 pairs of gloves in 6 sizes.
18/10 stainless steel.
Weight: 0.6 kg. Overall dim.: 555 x 137 x H.183 mm.

CHANGING ROOM

STERILISATION

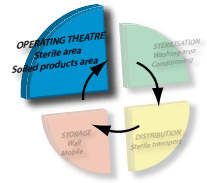

CLEAN AREA

Surgeon scrub-up



- > **Surgeon scrub-up**
ref 2 258 21 18
Complete station presenting hand-washing materials and surgical clothing.

Viewing station



- > **Viewing station**

Changing room



- > **Changing room**
The various size gowns along with disposable clothing are stored in baskets hooked onto wall supports.

Vertical clog rack



- > **Vertical clog rack**
ref 2 258 20 18
As patient records are not readily disinfected, in the operating theatre it is advisable to place them in a dedicated vertical rack.

Shoe rack



- > **Vertical shoe rack**
ref 2 258 10 18
Intended for sterilisation and operating theatre changing rooms. For 6 pairs of shoes in a small space. Fits onto a STERICADDIE trolley or wall mount.



- > **Horizontal shoe rack**
ref 2 258 09 18
Intended for sterilisation and operating theatre changing rooms. For 6 pairs of shoes in a small space. Fits onto a SteriCADDIE trolley or wall mount.

REMOVING SOILED GOODS



Stericaddie H.1100



- > **STERICADDIE trolley H.1100**
ref 2 220 54 18
(+ accessories)
The baskets or containers used to transport the instruments is returned on the same trolley to the central sterilisation unit.

Stericaddie H.1100



- > **STERICADDIE trolley H.1100**
ref 2 220 54 18
(+ accessories)

Trolley for decontamination bins



- > **Trolley for decontamination bins**
ref 2 220 39 18
(+ accessories)
18/10 stainless steel.
4 casters, including 1 with brake.
For 600x400 polypropylene bags.
Overall dimensions: 630 x 465 x H.845 mm.

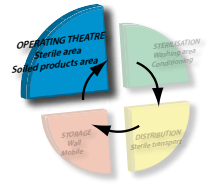

REMOVING SOILED GOODS ACCESSORIES

Bin rack



- > **Bin rack**
ref 2 259 01 18
18/10 stainless steel.
Overall dim.: 575 x 350 x H.145 mm.
Compatible with STÉRICADDIE
type 1/1, 2/3 and 1/2 bins.
Space between bottom wires: 30 mm.
Unit weight: 2.3 kg.
Permissible load: 40 kg.

Bag Holder



- > **Bag holder**
ref 2 258 80 18
18/10 stainless steel.
Overall dim.: 555 x 370 x H.267 mm.
Opening: 260 x 376 mm. Unit weight: 1.7 kg.
Permissible load: 20 kg. Bag capacity: 80 dm³.
Special characteristics: can be used with
plastic or cloth SUPER PIC LINGE or TRISAC
bags.

Lower screen









- > **Lower screen**
ref 2 220 08 18
(Factory-fitted by request)

DECONTAMINATION BINS

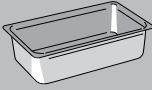
STERILISATION - OPERATING THEATRE

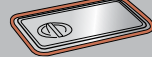
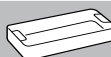

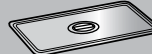
REMOVING SOILED GOODS

BINS		Dimensions in mm	Capacity in L	Reference	LIDS	INTRUMENT TRAYS	Reference
Stainless steel  1/1		530 x 325 x H.200	30	2 259 20 18	Stainless steel lid with seal 2 259 09 18 	For H.150 bins 	2 224 45 18 H.50
		530 x 325 x H.150	22	2 259 15 18	Stainless steel lid without seal 2 259 10 18 		2 224 48 18 H.90

> **Stainless steel lid with joint**
ref 2 259 09 18









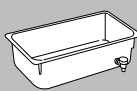

> **Stainless steel lid no joint**
ref 2 259 10 18

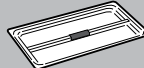
> **Steel bin 1/1. 30L**
ref 2 259 20 18

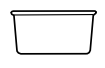
> **Nesco Bin**
Dim. 600 x 400 x 315mm
ref CA-37-6430-116



Important: for autoclaving, do not fit the stainless steel lids into the bins.

Polypropylene  1/1		H.200	27	2 259 20 50		For H.150 and H.200 	2 224 45 18 2 224 48 18	
		H.150		2 259 18 50 with drain valve			2 224 38 18	
	Polypropylene  2/3		354 x 325 x H.200	17,2	2 259 35 50			2 224 45 18 2 224 48 18
			x H.150	13	2 259 34 50			2 224 38 18
Polypropylene  1/2		265 x 325 x H.150	9,2	2 259 24 50		H.150 	2 224 15 18	



> **Polypropylene bin. 1/1. 27L**
ref 2 259 20 50
+ lid
ref 2 259 13 50









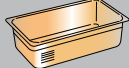

> **20L high-temperature polymer bin 1/1**
+ lid
ref 2 259 14 91 + 2 259 13 91

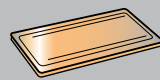

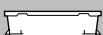
> **Drain valve**
ref 2 259 81 97

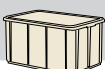
Important: polypropylene and polyethylene bins cannot be autoclaved.

BINS		Dimensions in mm	Capacity in L	Reference	LIDS	
High-temperature polymer 1/1 		530 x 325 H.150	20	2 259 14 91	2 259 13 91 	Sterilisation: all bins and lids are able to withstand temperatures between -40°C and +190°C. Excellent content visibility: translucent. Bin graduated in litres.
Polyethylene 		600 x 400 H.125	20	9 980 40 50	9 980 38 54 	Stackable, can be directly hooked onto StériCaddie trolley. Receives soiled, non-immersible equipment (dental light handle, small anaesthesia equipment, motors, etc.)
Polypropylene BINS 	600 x 400 H.330	60 L		2 259 54 61 2 259 55 61	no drain valve with drain valve	> 60L polypropylene bin with lid réf 2 259 55 61 

LOGISTICS

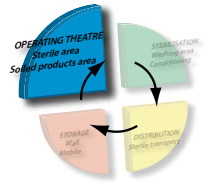

Collection



	Reference
1-bag model	CAH-202
2-bag model	CAH-203
3-bag model	CAH-204
4-bag model	CAH-205



TRISAC	Reference
1-bag model	0602012 LN
3-bag model	0602014 LN

> **Bilancia**
Laundry trolleyS with 1,2,3 or 4 removable and washable cotton bags equipped with PVC mass coloured lids with pedal opening system.

> **Trisac Alu**
CADDIE TRISAC is available for 1 to 3 bags and is suitable with most of the laundry drawstring bags.

Transport

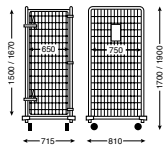

> **Roll Security**
ref : 4 495 72 97

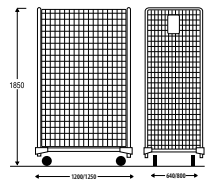

> **Transtock 1850H**
1200-800 Base
ref : 4 437 33 03
> **Transtock 1850H**
1250-640 Base
ref : 4 437 13 03

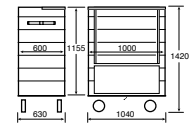

> **Shuttle cabinet**
ref. 2 290 27 11

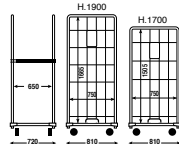
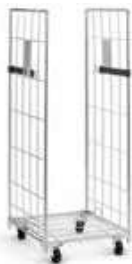

> **Roll Standard**
ref : 4 495 12 97

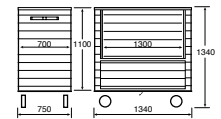

> **Shuttle cabinet**
ref. 2 290 39 11
Option : Divider 2 290 27 11
ref.: 2 290 98 12

Distribution

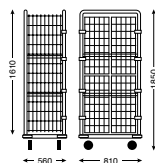

> **TRANSLINGE TROLLEY**
ref : 9 940 20 50
4 independent doors.
3 melamine-coated shelves
2 of which can be raised.
Capacity: 490 dm³.
Weight: 60 kg.
4 casters ø 125 mm,
2 fixed and 2 swivelling.

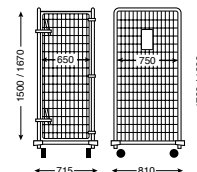

> **MONOBLOC SECURITY ROLL**
ref: 4 495 72 97
Galvanized steel tube and wire.
Permissible load: up to 500 kg.
Rubber casters: ø 125 mm, 2 fixed + 2 swivelling.
Capacity: 735 dm³.
Available in 2 heights:
1700 and 1900 mm.

PATIENTS FILES FLOW MANAGEMENT- TRANSPORT

Custom solutions fully adapted to your specific needs.



For over 50 years PCM HABILCLASS have designed and built customized products classification solutions, including trolley ranges, facilities for transport files, archives and correspondences.

The strength of PCM HABILCLASS is based on its ability to offer sustainable products and high quality of French manufacture. Our industrial expertise is recognized for many years.

Our skills and approach have seduced more than 8 000 customers.

Through our research & development department, we are able to design and adapt our trolleys for your specific requirements.

Located in the south of Paris, our factory with its production equipment allows us to answer easily for custom-made concepts.

Our flexibility and our industrial advanced expertise are unique asset to answer quickly and effectively to your personal requirements.

FILES FLOW



	STORE	CLASSI	PROTECT		
FUNCTIONS	•	•	•		
	CORRESPONDENCES	DOCUMENTS	ENVELOPES	FILES	RADIOGRAPHS
APPLICATION	•	•	•	•	•

Chart Colors

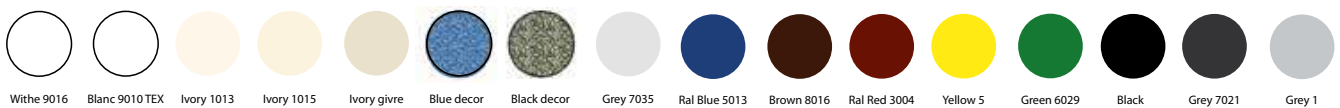

SOLANO RANGE

Secured trolley for A4 to A3+ format. Perfect for sitting or suspension files.
Adaptable screen support. Indoor wheels.

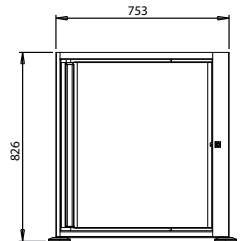

Width version :
423mm or 600mm

> IHSOL



Weight	37 to 52 kg
Overall dimension	H.820 to 1124 x L.571 to 753 x P.420 to 580
Frame	Electro-galvanized sheet steel corrosion resistant 10 and 20/10th and tube 30x30x1.5 and 60x30x2
Boxes	Electro-galvanized sheet steel corrosion resistant 10/10th
MODULARITY	
Number of levels	1 to 3 levels
Separators	14 to 20 boxes of 30mm per level
CAPACITY	
Effective interior dimensions per level	H.325 and 405 x L.423 and 605 x P.420 to 460
Documents format	A4 to A3+
MANOEUVRABILITY	
Wheels Ø125 ou 150*	4 Swivels Ø125mm or 150 mm of which 1 with brake and 1 with directional lock/1 swivel Polyamide cover Swivel on double balls bearing - Wires bumper Axis wheels on precision ball bearings - Polypropylene wheel body Non marking gray thermoplastic tyres
PERSONALIZATION	
Frame	Epoxy paint , tints according to color chart
Color	According to color chart

FILES FLOW

ALEXANOR RANGE

High flexibility of using trolley, perfect for patient files transport, secure, customizable, A4 to A3+ format, several levels available, Aluminium box.

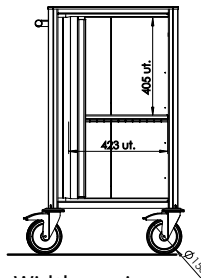

Width version :
423mm

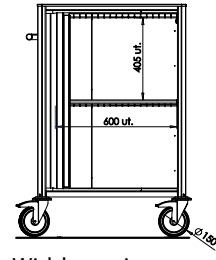

Width version :
600mm

> **IHALE**
(+ accessories)



Weight	36 to 58 kg according to models and equipment
Overall dimension	H.1030 to 1560 x L. 5637 or 814 x P.527 to 647
Frame	Anti-corrosive electro-galvanized steel sheet 10 and 20/10th and aluminium 12/10th
Boxes	Aluminium 12/10th
MODULARITY	
Number of levels	1 to 2 Levels
Separators	14 to 40 boxes de 30mm per level
CAPACITY	
Effective interior dimensions per level	H.325 to 405 x L.423 to 600 x P.420 to 540
Documents format	A4 to A3+
MANOEUVRABILITY	
Wheels Ø125 ou 150*	Swivel casters with wheels, bumper Ø125 or 150 mm / 1 to bldirectional lock and choice of 1 brake /polyamide cover - Swivel on double ball bearing. Polypropylene body wheel Non-marking gray thermoplastic tyres with bumper-wires -Axis wheels on precision ball bearings
PERSONALIZATION	
Frame	High durability epoxy paint, 17 tints according to color chart, treatment following external need
Color	Epoxy paint , tints according to color chart According to color chart

ALEXANOR TROLLEY ACCESSORIES

Full solutions measure up to you needs!

Writing tablet

Reference	IZALETE
Overall dimension	H 16 x L 558 à 735 x P 479 à 599
Frame	Electro-galvanized steel sheet 10/10th
Weight	2.40 to 3.90 kg
Color	According to color chart

Delivered assembled



Tablet computer

Reference	IZALETPC
Overall dimension	H95xL558 à 735xP 479 à 599
Frame	Electro-galvanized steel sheet 10/10th
Weight	2.90 to 4.37 kg
Color	According to color chart

Delivered assembled

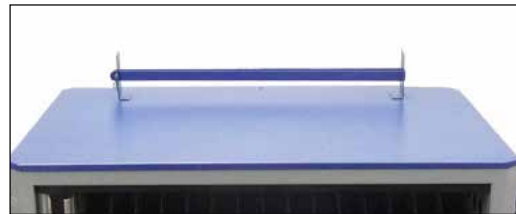

Flip- tablet

Reference	IZALETA
Overall dimension	L 415 à 535 x P 380 x EP 60
Frame	Aluminium 20/10e
Weight	3 to 3.20 kg
Color	According to color chart

Delivered assembled



Sorter 3 or 5 boxes

Reference	IZALETR
Overall dimension	H401à 609xL314xP136
Frame	Aluminium 20/10e
Weight	2.40 to 3.25 kg
Color	According to color chart

Delivered assembled



Storage Basket

Reference	IZALEPA
Overall dimension	H 102 x L 304 to P 138
Frame	Aluminium 20/10e
Weight	0,80 kg
Color	According to color chart

Delivered assembled



Magnetic bottle holder

Reference	IZDV3410
Overall dimension	L 72 x P 72 x H66
Frame	Electro-galvanized steel sheet 10/10th
Weight	0,170 kg
Color	According to color chart

Delivered assembled



Pencil box

Reference	IZDV3585
Overall dimension	L 202 x P 52 x H 26
Frame	Electro-galvanized steel sheet 10/10th
Weight	0,180 kg
Color	According to color chart

Delivered assembled



SECURED TROLLEYS

PATIENTS FILES FLOW MANAGEMENT- TRANSPORT

GAMME LIPS

High flexibility of using, this trolley is perfect for patient files transport, secure, customizable.

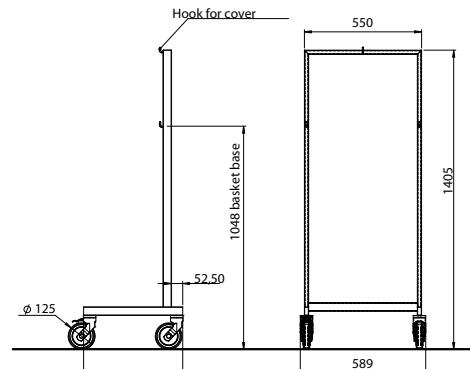

> IHLIP
(+ accessories)

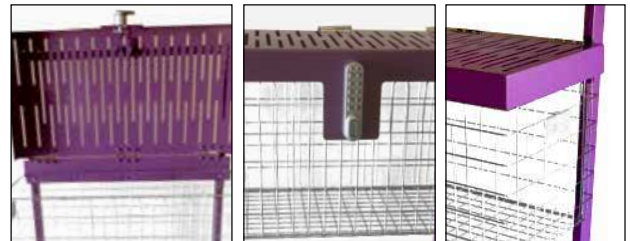

Weight	20 to 24 kg (steel version) - 15 to 20 kg (Stainless steel)
Overall dimensions	Standard - HT 1500 x P 465 x L550
Frame	Electro-galvanized steel sheet 20/10e or Stainless Steel - Steel tube 40x20x1.5
Basket	Electro-galvanized steel sheet or stainless steel 18/10
MODULARITY	
Number of levels	1 to 4
Basket	Mobile or static
Perforing in baskets	Electro-galvanized steel sheet 20/10e section Ø30
CAPACITY	
Dimensions rails	Standard 600 x 400 x 300
Documents formats	A4 à A3+
MANOEUVRABILITY	
Wheels Ø125 or 150	Swivels Ø125mm Polyamide cover Gray ral 7035 - Screw: CHC M10x40 of which 1 with brake
PERSONALIZATION	
High durability epoxy paint, tints according to color chart	

GAMME JASIU

Developed from a backbone which tolerate 1 to 2 rails. Modular and adaptable dimensions according to file sizes, in A4/A3+ on 2 levels.

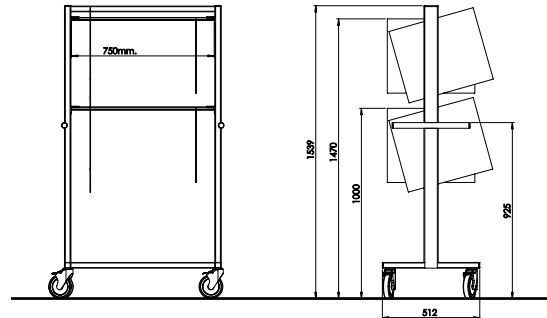

> IHJAS

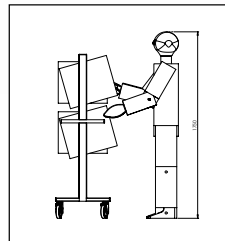

Please don't hesitate to contact us for any request

Weight	17 to 20kg
Overall dimensions	H.1155 to 1539 x L.854 x P.512
Frame	Electro-galvanized steel sheet 20/10e mm - Steel tube 30x30x1.5
Writing shelf	Electro-galvanized steel sheet 10/10th
MODULARITY	The frame is modular and could be configured in A4 / A3 or A3 2 levels. The dimensions are adaptable depending on the files format, users need and locals constraints.
Number of levels	1 to 3
Suspension rail	1 to 2
Formats A3 / A4	•
CAPACITY	
Dimensions rails	616/726/956/1066
Documents formats	A4/A4+ à A3/A3+
MANOEUVRABILITY	
Wheels	Swivels Ø125mm of which 1 with brake and 1 with directional lock, Polyamide cover - Swivel on double ball bearing - Wires bumper - Axis wheels on precision ball bearings Polypropylene wheel body Non marking gray thermoplastic tyres
PERSONALIZATION	High durability epoxy paint, tints according to color chart

OPEN TROLLEYS

PATIENTS FILES FLOW MANAGEMENT- TRANSPORT

MACHAON RANGE

Trolley for files transport with a high flexibility of using. Perfect for patient files, customizable and adaptable from A4 to A3+ format. 1 to 3 levels.



> IHMAC
(+ accessories)

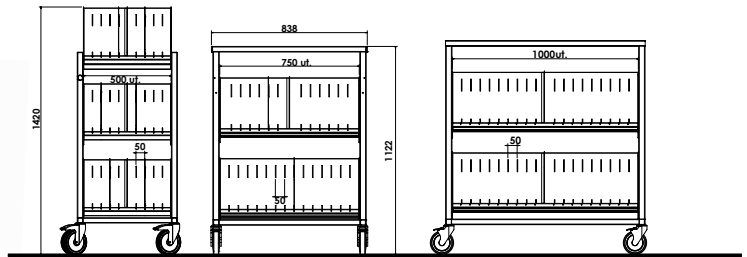

Width version :
500mm

Width version :
750mm

Width version :
1000mm



Weight	17 to 56 kg according to models and equipment
Overall dimensions	H.1000 to 1599 x L. 593 to 1086 x P.480 to 565
Frame	Electro-galvanized steel sheet 20/10e and tube 30x30x1.5
Writing shelf and baskets	Electro-galvanized steel sheet 10/10th
MODULARITY	
Number of levels	1 to 3 levels
Baskets	Fixed
CAPACITY	
Useful interior dimensions per level	H.285 à 410 x L.500-750-1000 x P.480 à 565
Documents formats	A4 to A3+
MANIABILITY	
Wheels Ø 125/150mm*	4 casters entirely disassembled of which 2 swivels. 1 with brake and 1 to directional lock -Polyamide cover - caster on double ball bearing - Wires bumper - Axis wheels on precision ball bearings - Polypropylene wheel body - Non marking gray thermoplastic tyres (* The wheels are designed for use on interior floor)
Wheels Ø 200mm*	4 swivels of which 1 with brake - 4 swivels of which 1 with directionnel lock and 1 with brake 4 swivels of which 2 to directional lock and 1 to brake - 2 fixed and 2 swivels of which 1 brake Polypropylene wheel body -Axis wheels on precision ball bearings. Non marking gray thermoplastic tyres - Galvanized steel cover to platinum
PERSONNALIZATION	
Frame	Epoxy paint high durability , 17 tints according to color chart, treatment following external need
Baskets	Electro-galvanized steel sheet : 20/10th and steel tube 30 x 30 x 1,5mm and 30 x 1,5mm Electro-galvanized steel sheet: 20/10th surface coating corrosion resistant High durability epoxy paint according to color chart - 17 Standard tints available

ACCESSORIES MACHAON TROLLEY

Container with or without lock

Reference	IZMAC
Overall dimensions	H.350 to 440 x L.500,750 or 1000 x P.380 to 530
Arrangement	Fixed or mobile
Frame	Electro-galvanized steel sheet 10/10th
Weight	4 to 11,60kg
Color	According to color chart
Delivered assembled	

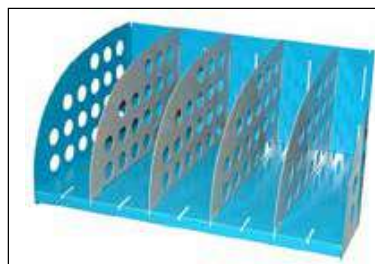

Writing shelf and basket

Reference	-	IZMAC
Overall dimensions	L.504 to 650 x P.380 to 490	H.120 or 180 x L.502 or 202 x P.462 ou 202
Frame	Electro-galvanized steel sheet 10/10th	
Weight	2,5 to 3,4kg	3,9 and 1,67kg
Color	According to color chart	
Delivered assembled		

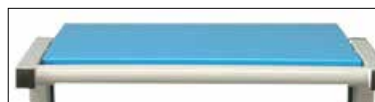

Drop down shelf and vertical divider

Reference	-	IGMET, IGALU ou IGABS
Overall dimensions	L.360 x P.380 to 500	H.254 à 334 x L.377 to 537
Arrangement	Settles to the left or right	Fixed or mobile
Frame	Electro-galvanized steel sheet 10/10th	Electro-galvanized steel sheet, Alu, ABS 10/10th
Weight	2,6 to 3kg	0,6 to 1,4kg
Color	According to color chart	According to color chart
Delivered assembled		Delivered assembled



Magnetic pencil box

Reference	IZDV3585
Overall dimensions	H.26 x L.202 x P.52
Frame	Electro-galvanized steel sheet
Weight	0,180kg
Color	According to color chart
Delivered assembled	



Rubber bumper

Reference	IZDV3726
Frame	Rubber
Weight	0,2kg



OPEN TROLLEYS

PATIENTS FILES FLOW MANAGEMENT- TRANSPORT

FLORELLA RANGE

Modular visit trolley to store and carry A4 to A3+ files. 1 level available.

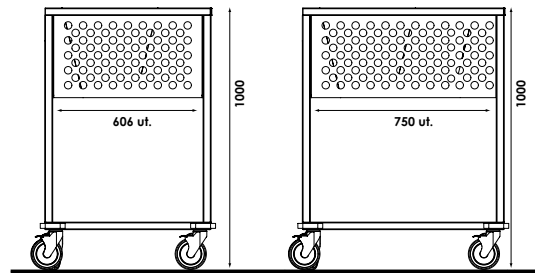

Width version :
606mm

Width version :
750mm

> IHFLO
(+ accessories)



Weights	24 kg
Overall dimensions	H.1000 x L.606 x P.1139 to H.1000 x L.750 x P.420
Frame	H.1000 x L.750 x P.420
Baskets	Steel sheet corrosion resistant 10 and 20/10th
MODULARITY	
Number of levels	1 level
Perforing in baskets	With or without perforation
CAPACITY	
Useful interior dimensions per level	H.350 x L.540 x P.1000 and H.310 x L.354 x P.600
Documents formats	A4 to A3+
MANIABILITY	
Wheels	4 casters entirely disassembled of which 2 swivels. 1 with brake and 1 to directional lock -Polyamide cover - caster on double ball bearing - Wires bumper - Axis wheels on precision ball bearings - Polypropylene wheel body Non marking gray thermoplastic tyres
PERSONNALIZATION	
Frame	High durability epoxy paint , 17 tints according to color chart, threatment following external need
Baskets	Electro-galvanized steel sheet : 10 and 20/10th and steel tube 30 x 30 x 1,5mm and 30 x 1,5mm Gray epoxy coating n°1 Electro-galvanized steel sheet : 10 and 20/10th or steel wire electroplated coatings Corrosion resistant High durability epoxy paint according to color chart- 17 standard tints available

FILES FLOW

ZORHA RANGE

Developed from a backbone which tolerate 1 to 3 movable baskets. Basket dimensions are modular according to format files: A5 to A3+.

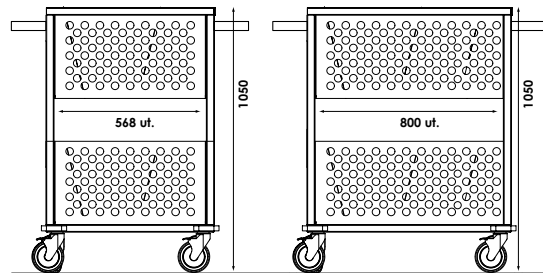

Width version :
568mm

Width version :
800mm



> **IHZOR**
(+ accessories)

Weights	25 kg
Overall dimensions	H.1050 à 1200 x L.534 to 978 x P.420 à 680
Frame	Electro-galvanized steel sheet 20/10e mm - steel tube 30x30x1.5
Baskets	Steel sheet corrosion resistant 10 and 20/10th
MODULARITY	
Number of levels	2 levels
Perforing in baskets	With or without perforation
CAPACITY	
Useful interior dimensions per level	H.150 or 300 x L.534 x P.400 à 536
Documents formats	A4 to A3+
MANIABILITY	
Wheels	4 casters entirely disassembled of which 2 swivels. 1 with brake and 1 to directional lock - Polyamide cover - caster on double ball bearing - Wires bumper - Axis wheels on precision ball bearings - Polypropylene wheel body Non marking gray thermoplastic tyres
PERSONNALIZATION	
Frame	Epoxy paint high resistant , 17 tints according to color chart, threatment following external need Electro-galvanized steel sheet : 10 and 20/10th and steel tube 30 x 30 x 1,5mm and 30 x 1,5mm Gray epoxy coating n°1
Baskets	Electro-galvanized steel sheet : 10 and 20/10th or steel wire electroplated coatings Corrosion resistant High durability epoxy paint according to color chart- 17 standard tints available

COMPUTER TROLLEY

FILES FLOW MANAGEMENT- COMPUTER

ATHALIA RANGE

IT trolley mounted on jacks, which allows you to set, carry and secure an IT work station with an absolute autonomy (screen support, computer system unit, batteries in option, movable keyboard).



> ATH004



> ATH005
(+ accessories)

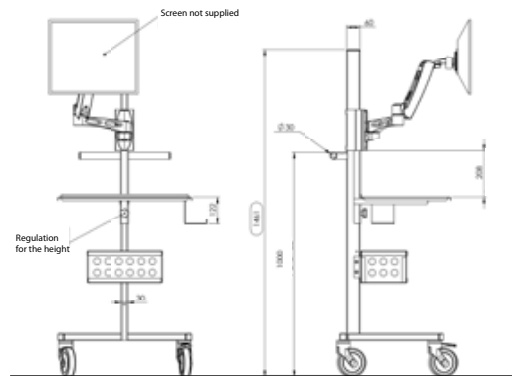

Optional battery. Contact us for any enquiries

Weight	40Kg
Overall dimension	H.1673(hIGH) and 1421 (low) L.620 x P.614
Frame	Corrosion resistant electro-galvanized steel sheet 10 and 20/10th
Shelf	Antibacterial treated resin shelf
MODULARITY	
High shelf	986 to 1238mm
Low focal	1484mm
Height adjustment	cylinders 170N
Keyboard on sliding shelf	•
Outlet block 230V/50Hz - 10/16A +T with inter. M/A	•
Storage Basket	•
CAPACITY	
Boarding	Screen +CPU +keyboard + mouse
Autonomy	Battery Pack on converter 230V/AC
MANIABILITY	
Wheels	Swivels 150 mm of which 1 to brake Polypropylene wheel body Non-marking gray thermoplastic tyre
PERSONNALIZATION	
Column Legs	Epoxy paint, Tints according to color chart

ATHALIA RANGE WITH OR WITHOUT SHELF

IT trolley mounted on jacks, which allows you to set, carry and secure a laptop.

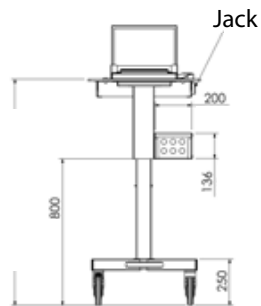

> ATH007

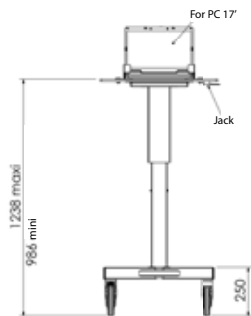

> ATH006



Weight	22kg
Overall dimension	H.1238(high) and 986 (low) L.620 x P.614
Frame	Corrosion resistant electro-galvanized steel sheet 10 and 20/10th
Shelf	Antibacterial treated resin shelf
MODULARITY	
High shelf	986 to 1238mm
Low focal	•
Height adjustment	•
Keyboard on sliding shelf	Cylinders 120N
Outlet block 230V/50Hz - 10/16A +T with inter. M/A	•
Storage Basket	•
CAPACITY	
Boarding	Laptop + padlock
Autonomy	-
MANIABILITY	
Wheels	Swivels 150 mm of which 1 to brake Polypropylene wheel body Non marking gray thermoplastic tyres
PERSONNALIZATION	
Column Legs	Epoxy paint, Tints according to color chart

STORAGE FURNITURE

FILES FLOW MANAGEMENT - STORAGE

CARDINAL RANGE

Trolley for A4 to A3 format or suspended files which allows you to have a direct access to your files.

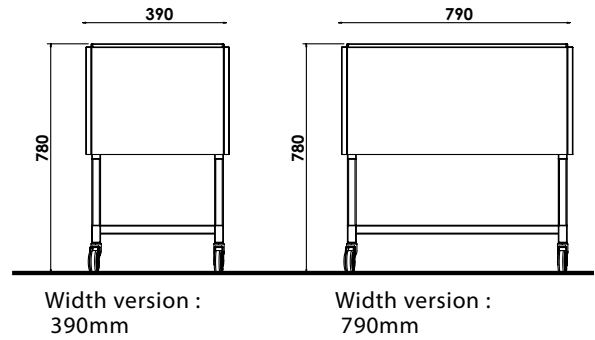

> IHCAR

Weight	15 to 48 kg
Overall dimensions	H.700 to 950 x L.390 to 790 x P.572 to 880
Materials	Electro-galvanized steel sheet 10/10e mm - Steel tube 30x30x1.5 and 60x30x2
MODULARITY	
Number of levels	2 levels with or without lock drawers. ABS dividers or movable metallic. With or without lid
Conception	Variation dimensions according to format, arrangements, sitting position in use or standing and the consumer needs.
Bins	Serrated or plane or suspension rail
CAPACITY	
Effective bins dimensions	H.220 to 460 x L.220 to 600 x P.400 to 1000
Documents Format	A4 to A3+
MANIABILITY	
Wheels	4 swivelling wheels Ø 75mm or 4 wheels Ø 125 entirely demountable of which 2 swivel, 1 to brake and 1 to directional lock - Polyamide chape - Swivel on double balls bearing - Polypropylene wheel body - Non-marking thermoplastic rubber tyre - With bullet wires - Axis wheels on precision ball bearings
PERSONNALIZATION	
Frame	Gray Epoxy Coating n°1 or colors according to color charts
Removable shelf	Electro-galvanized steel sheet : 12/10th Surface coating corrosion resistant High durability epoxy paint according to color chart - 17 Standard tints available

FILES FLOW

CUPIDO RANGE

Steel cube which allows you to organise and protect your A3+ files. Possibilities to superimpose until 3 static boxes.

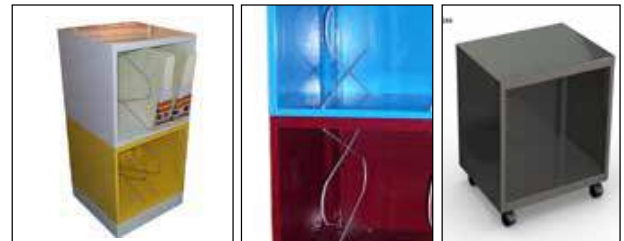
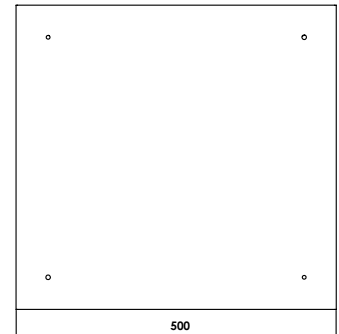
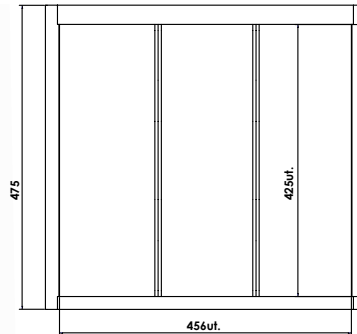

> IHCUP

Weights	15kg (2 boxes)
Overall dimensions	H.475 x L.500 x P.500
Materials	Electro-galvanized steel sheet 10/10e
MODULARITY	
Nombre d'éléments	1 to 3 superposed cubes
Conception	Monoblock box/configuration according to constraints arrangement
Bacs	Monoblock box/perforated for 8 metal separators
CAPACITY	
Effective bins dimensions	H.425 x L.458 x P.499
Documents Format	A3+
MANIABILITY	
Wheels	Equipped wheels diameter 50mm
PERSONNALIZATION	
Frame	High durability epoxy paint , 17 tints according to color chart, treatment following external need
	Tints according to color chart

STORAGE FURNITURE

FILES FLOW MANAGEMENT - STORAGE

GAMME ABELIA

Organize and classify all kind of files with this modular and ergonomic ABELIA range. Several layout available with drawers. Custom-made drawers and boxes according to our color chart.

Product benefits

2 or 3 ranks width, 50kg maximum per drawers; 2 ABS divider per rank. Drawers mounted on ball bearing telescopic slides for a full opening. Locking security system which allows to open one drawer in the same time. Plus one general condemnation lock



> ICFOC

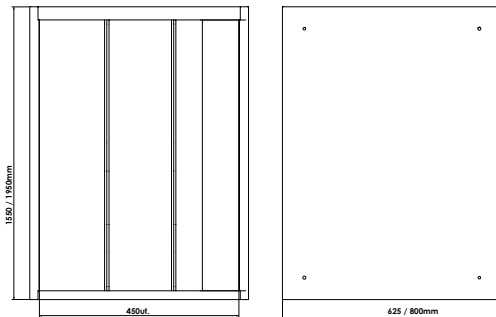

Depth Version :
450mm

Depth Version :
625mm (max.800mm)



Weight	15kg (2 boxes)
Overall dimensions	H.maxi 1950 H.recommended 1550 x L.800 x P.450 or 625
Materials	Electro-galvanized steel sheet 10/10nth and 8/10nth
Overture	Locking Security System, opening one drawer at a time.
MODULARITY	
Drawers	According to the needs, drawers mounted on Telescopic ball bearing slides.
Conception	Monoblock box/Configuration according to constraints arrangement/built-in handle
Bins	Monoblock box
CAPACITY	
Useful interior dimensions per level	H.x L. x P.405 or 580
Documents Format	Facilities for , sitting, suspended or panoramic files
MANOEURVRABILITY	
Base	Tubular base in option T or cabinet base
PERSONNALIZATION	High durability epoxy paint , 17 tints according to color chart, threatment following external need
Frame	Colors according to chart

ADONIS RANGE

All files format adaptable to this storage cabinet according to your need.
1 to 6 levels. Sliding door. Bracket to maintain files. A5 to A3+ format.



> IHADO

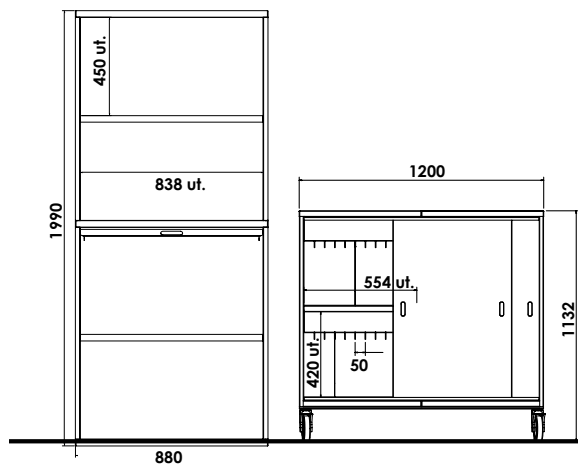

Width version :
838mm

With wheels :
1200mm with wheels



Weight	14 to 223kg depending on arrangement
Overall dimensions	H.225 to 1980 x L.500 à 1000 x P.250/360/520
Materials	Electro-galvanized steel sheet 10/10e
Opening	According to configuration and customer needs
MODULARITY	
Extractable shelf	In option
Conception	monoblock box/configuration according to constraints arrangement
Box	Monoblock box stackable
CAPACITY	
Documents Format	Arrangements for fixed suspended, or panoramic files
PERSONNALIZATION	
Frames	High durability epoxy paint , 17 tints according to color chart, threatment following external need Colors according to chart

STORAGE FURNITURE

FILES FLOW MANAGEMENT - SHELVING

TUBULAR RACKING RANGE

This tubular racking offer a storage or filling structure for a weight average and also an excellent stability.



ALUMINIUM RACKING RANGE

PCM HABILCLASS offer you these aluminium racking for pharmacy sector with various design solutions (bins...).



STEEL SIDE WALL RACKING RANGE

This steel side wall racking is the solution for your filling: esthetic, strong and flexible.



DIABLO RANGE

Modular transport trolley, multifunction suitable for your A4-A3+ files, correspondences or any other documents.

Diablo



> IH DIA

Balcana



> IHBAL

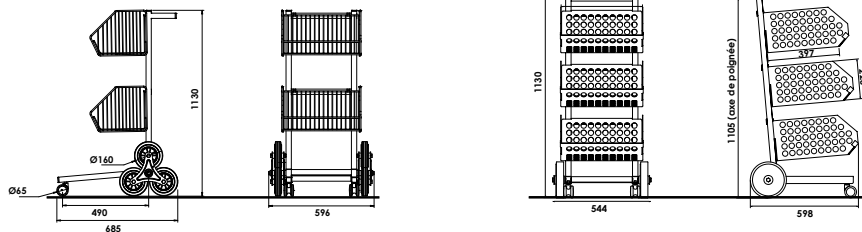

	DIABLO	BALCANA
Weight	26 kg	17KG
Overall dimensions	H1130 x L544 x P598	H1130 x L544 x P598
Frame	steel wire electroplated coatings in basket	steel wire electroplated coatings in basket
MODULARITY		
Number of baskets	2 To 3 Baskets	To 3 Baskets
Removable baskets	•	•
Steel wire baskets	Except IH DIV388	Except IH DIV504
CAPACITY		
Effective Interior dimensions per level	H220 x L450 x P400 mm	H220 x L450 x P400 mm
Documents format	A4 to A3+	
MANIABILITY		
Rear wheels	Fixed Ø200mm Polypropylene wheel body Non marking gray thermoplastic tyres	
Front wheels	Swivels Ø65mm	
PERSONNALIZATION		
Frame	Electro-galvanized steel sheet : 20/10th Gray epoxy Coating n°1	
Baskets	Electro-galvanized steel sheet : 20/10th Surface coating corrosion resistant High durability epoxy paint according to color chart - 17 standards tints available	

FILES FLOW MANAGEMENT - MULTIFUNCTION

COLIAS RANGE

Multifunction transport trolley suitable for your files, correspondences or other documents.

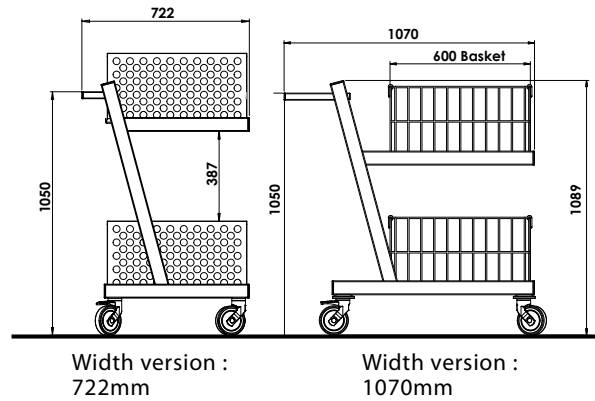

> IHCOL TROLLEY WIRES BASKETS

Trolley with
telescopic
lower bin
5 wheels
version



4 wheels
version



Weight	21kg (with wires baskets) and 29kg (Metal bins)
Overall dimensions	H1216 x L499 x P722
Baskets structure	Steel wire / steel sheet 20/10th
MODULARITY	
Number of levels	2 levels
Removable baskets	•
Perforation in baskets	For the trolleys REF : IHDIV361 and IHDIV476
CAPACITY	
Effective Internal dimensions per level	Bin A4 : High / low level : H.240xL.330xP.789/H.130xL.330xP.789 - Bin A3+ : H.300xL.400xP.600
Documents formats	A4 to A3+
MANIABILITY	
Rear wheels	Swivels Ø125mm of which 1 with brake Polypropylene wheel body Non marking gray thermoplastic tyres
Front wheels	Swivels Ø125mm
PERSONNALIZATION	
Frame	Electro-galvanized steel sheet : 20/10th and steel tube 30 x 30 x 1,5mm and 30 x 1,5mm Epoxy gray coating n°1
Baskets	Electro-galvanized steel sheet : 20/10th or steel wire electroplated coatings Surface coating corrosion resistant High durability epoxy paint according to color chart - 17 standard tints available

FILES AND PLASTIC SLEEVE

We can suggest you tear resistant models on the whole range, white color, 150/175 or 200g. A translucent ICE tear resistant models in 170/200g or 270g. They are custom made and indexable.

Chrysalide

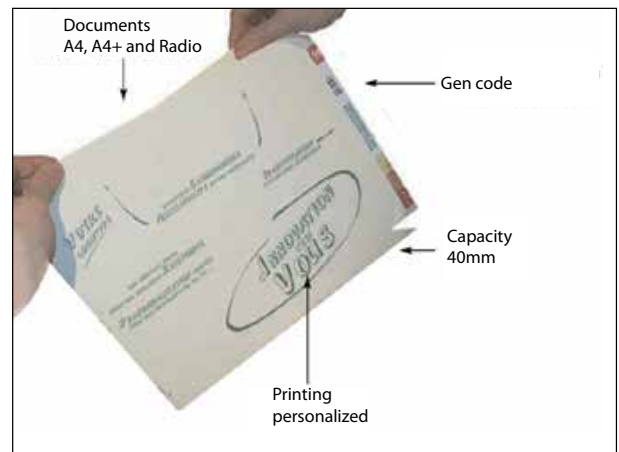

> CHRYSALIDE

Product benefits

Innovative is the best adjective to use with this Chrysalide sleeve. Its ergonomic cut makes easier the opening and accessibility to your documents into. Resistant, its thickness changes according to your documents quantity into.

Fully custom made, it exists for all size files: A4, A4+, A3 or radiography.



Cocon

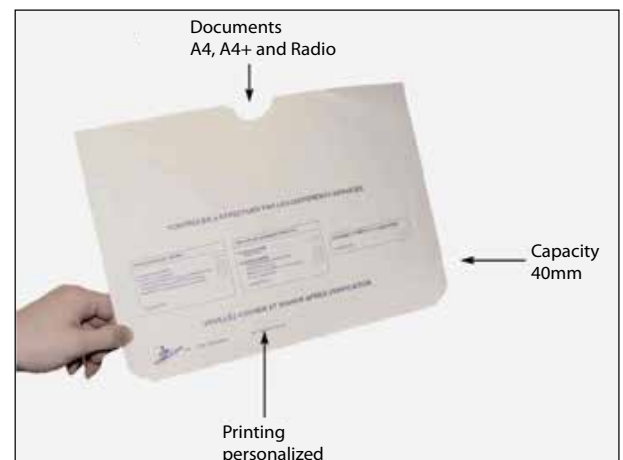

> COCON

Product benefits

The COCON sleeve ergonomic cut allows a file swelling without distortion nor rear. its thickness changes according to your documents quantity into. You will use only the necessary space.

Fully custom made, it exists for all size files: A5, A4, A4+, A3 or radiography.

ADMINISTRATIVE FILES

ADMINISTRATIVE FILES - FILES CLASSIFICATION

CLASSIFICATION SYSTEM

We can suggest you tear resistant models on the whole range, white color, 150/175 or 200g. A translucent ICE tear resistant models in 170/200g or 270g. They are custom made and indexable.

Ecoclass



> ECOCLASS

Product benefits

No more broken suspended files.
PCM HABILCLASS has got the solution: ECOCLASS files.
Standard A4 format put on the shelf in cardboard, thickness until 30mm and inside flap.



Thais

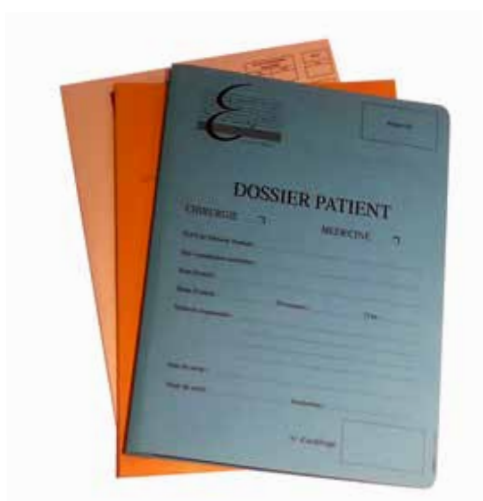

> THAIS

Product benefits

THAIS file is perfect to put in order your files. PCM HABILCLASS suggest you this file for medical sector, administrations, companies and liberal professions.

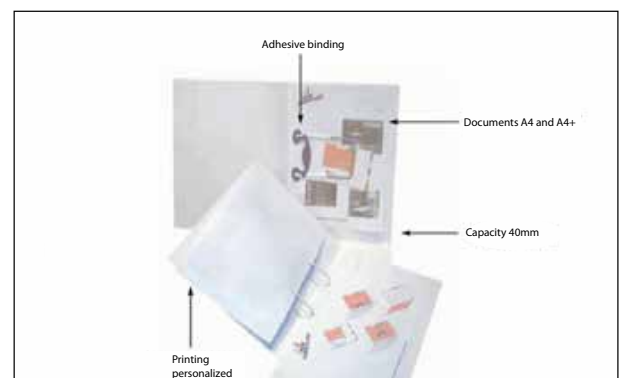

LABEL RANGE

To save time in your research and classify your files

Millesimes



Alphabets



United colors



Numericals



Label dispenser



Product benefits

Three indexation systems are customizable according to your need: alphabetic, numeric and alphanumeric. It's also possible to provide you an indexation based on month and day or all your organisation would require.

Color paper / Range of colors

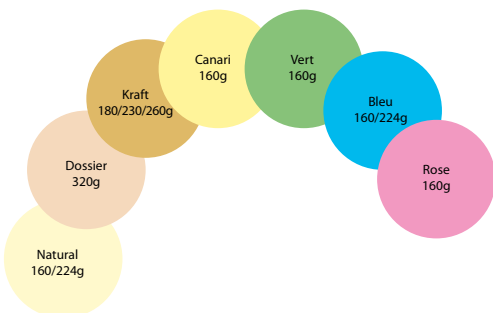

> COLOR PAPER

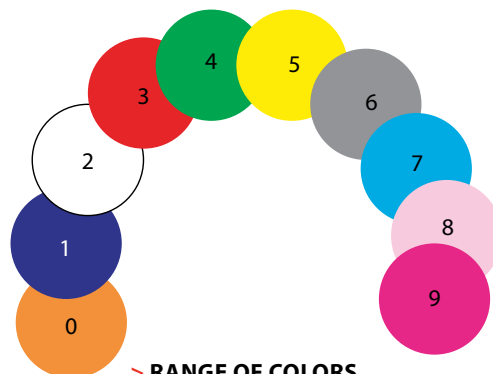

> RANGE OF COLORS

COLLECTION - SUPPLY

A complete solution of the logistics hospital.



HOSPITAL LOGISTICS



LINEN AND SERVICE RANGE



Roll Standard & Security



> **ROLL Standard**
ref : 4 495 12 97



> **ROLL Security**
ref : 4 495 72 97

Product benefits

For handier storage, dismantled panels fit into a single Caddie® roll container and the bases can be stacked together. For storage and empty return purposes, 12 Caddie® standard roll take up the same space as two fully assembled. Tested for loads of 500 kg.

Transtock

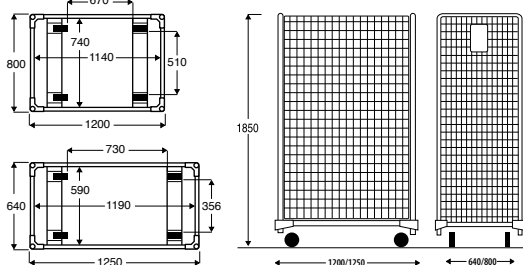

> **TRANSTOCK 1850H / 1200-800 Base**
ref : 4 437 33 03

> **TRANSTOCK 1850H / 1250-640 Base**
ref : 4 437 13 03

Product benefits

Working height: 1635 mm.
Equipped with ø 125 mm casters.
Overall height: 1850 mm.
Equipped with ø 160 mm casters.
(on request) Overall height: 1890 mm.

Shuttle cupboard

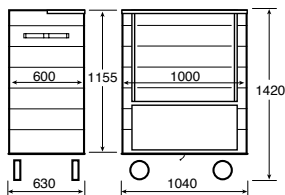

> **Shuttle cupboard**
ref. 2 290 27 11
An optional separator

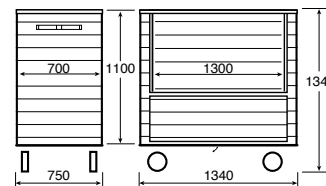

> **Shuttle cupboard**
ref. 2 290 39 11



Bactainer 180 L and 360 L

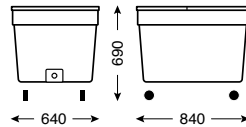

> **Bactainer 180L**
ref. 4 465 28 50

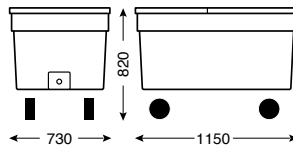

> **Bactainer 360L**
ref. 4 465 38 50

Product benefits

Rigid and sturdy polyethylene construction
Load capacity: 200 kg
Equipped with a bung hole for emptying

Bactainer Alu

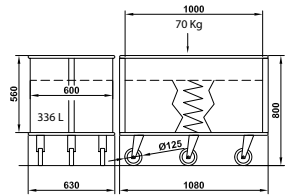

Product benefits

Mobile spring driven self levelling inlay, moves according to the loaded weight.

Sirio



> **Sirio**



> **Sirio Ergo**

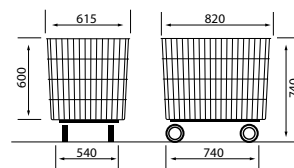
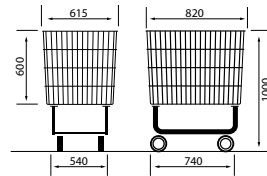

Product benefits

Fully welded steel wire structure with anti-corrosion white finish.
Raised tube base on Ergo. 4 swivels wheels.

Deneb



> **Easy**



> **Hydro**

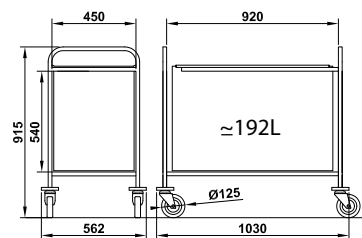

Product benefits

A slim line to ease corridor traffic, composite casters for silent progress, a high ergonomic handle and a very high capacity: CADDIE SAC EASY and HYDRO (with a water repellent bag) are essential to any hotel's linen management.

LINEN AND SERVICE RANGE

Aurora inox



Product benefits

Each centimetre counts and has to help the daily operations towards an efficient and comfortable service for your guests. It is with pride and pleasure that we introduce our range of compact equipment!

Europa 500 T



Gemelli



Product benefits

Capitalizing on decades of experience, the 2015 edition TAHITI has been improved! With new HPL paneling and composite casters, the TAHITI is now lighter, sturdier and quieter than ever. A broad range of options will enable you to configure the perfect equipment for your operations.

Europa 700 T (Picture with options)



Marcab 4



Product benefits

Two inner height-adjustable shelves, upper protection frame and 2 castors with brake included. A broad range of options will enable you to configure the perfect equipment for your operations.

Europa 900 T



LOGISTICS RANGE



Trolley M.E.R.



Reference	CAP-512016-1 plate tray	CAP-512016-2 plate tray
Weight	44kg	40kg
Overall dimensions	L.710 X P.1019 X H.1017 MM	
Frame	Galvanized steel tube	
Spring upper tray	Overall dim : 710 X 1019 MM	
MODULARITY		
Handle	Protective oval	
Conception	Steel tube frame	
Wheels	4 Wheels 125mm with silent rubber-tired	
CAPACITY		
Payload	100kg	
PERSONNALIZATION		
Options	High durability epoxy paint, 17 tints according to color chart	
	Call us	

Mobilinge

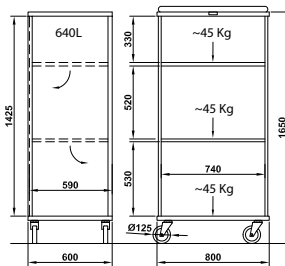

Product benefits

CADDIE MOBILINGE is a versatile mobile cupboard fully made out of anodized aluminum. For the delivery of clean folded linen, MOBILINGE has 3 levels (which 2 foldable shelves) and an interior protected from pollution thanks to the roll down curtain tightened on the frame by velcors straps. 2 fix and 2 swivel castors.

Caddienox

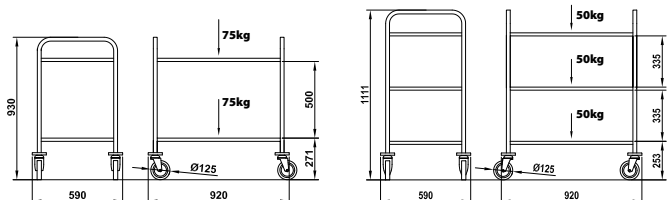

Caddienox 2

Caddienox 3

Product benefits

Lightweight, convenient and silent stainless steel service carts.

FRONT OFFICE

A solution to ensure you patients reception.



FRONT OFFICE



RECEPTION

GUIDFLEX RANGE



Guidflex spiga 70



Type	Ref.	Finition	Dimensions: (mm)	Compatible info pan. A3 & A4 ?	Weight Kg:
SPIGA 70	CAH-603	Chromed.	Diam Pied / Foot diam: 320	Yes	9kg
	CAH-604		Diam Tube: 70 H: 1050.	Yes	

Product benefits

GUIDFLEX SPIGA70 posts and GUIDFLEX CORD ropes guide your hosts and visitors with style and presence. As an essential asset to your lobby area, our posts combine a large 70mm diameter, luxurious finish and a good stability.

All versions are compatible with GUIDFLEX INFO panels A4 and A3.

Guidflex Cord



Type	Ref.	Finition cordon	Finition	Lenght of rope (mm)
CORD R CR	CAH-611CR	Red	Chromed Steel	1500mm
CORD R BR	CAH-611OTT	Red	Brass finish	
CORD B CR	CAH-612CR	Blue	Chromed Steel	
CORD B BR	CAH-612OTT	Blue	Brass finish	
CORD N CR	CAH-613CR	Natural	Chromed Steel	
CORD N BR	CAH-613OTT	Natural	Brass finish	
CORD Z CR	CAH-614CR	Black	Chromed Steel	
CORD Z BR	CAH-614OTT	Black	Brass finish	

Guidfex retraX



Type	Ref.	Post material (Diam.70mm- H.1050mm- 8,5kg)	Finition	Lenght of rope (mm)
retraX CR	CAH-642	Chromed steel	Red, blue or black.	2700mm
retraX BK	CAH-643	Black		
retraX BR	CAH-645	Brass finish steel		

Product benefits

GUIDFLEX retraX's flexibility and ease of use will be your daily ally. The range offers a vast choice of finishes and color options as well as a 2700mm belt to avoid congestion effect caused by too many posts. Postfree model for direct wall mounting available upon request.

INFORMATIONS

Guidflex info A4 & A3



Type	Ref.	Inner and outer frame :	Post material	Frame size	Printing format
INFO A4 BK	CAH-1-603	Inner : Black/ Outer: Sheen aluminum	Diam. 70 mm Chromed steel	A4 : 210 × 297mm A3 : 297 × 420mm	All frames are fully versatile for landscape and portrait print-outs
INFO A4 BR	CAH-1-604	Inner : Golden /Outer: Sheen aluminum	Diam. 70 mm Brass finish steel		
INFO A3 BK	CAH-2-603	Inner : Black/ Outer: Sheen aluminum	Diam. 70 mm Chromed steel		
INFO A3 BR	CAH-2-604	Inner : Golden /Outer: Sheen aluminum	Diam. 70 mm Brass finish steel		

Product benefits

Elegance, ergonomic reading, stability and cleanliness and flexibility and ease of use .

Exhibition screen

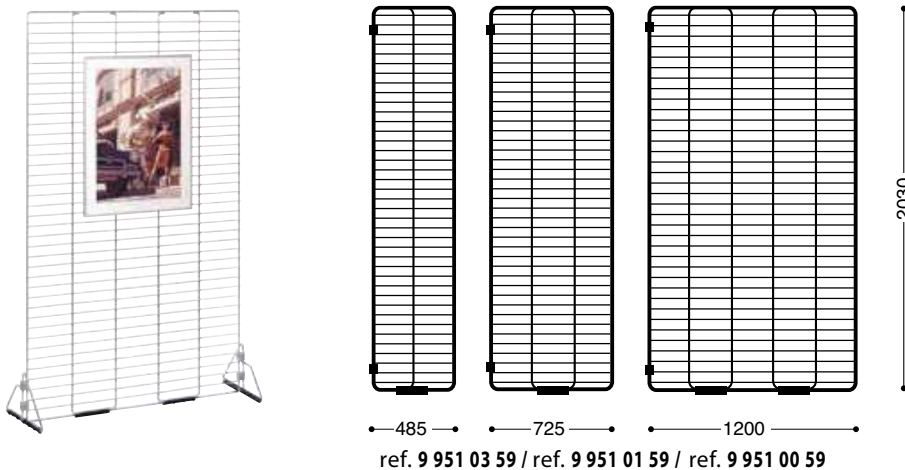

Product benefits

- Large front/back presentation area
- Varnished galvanized steel wire structure, able to withstand repeated handling
- Simple no-tool assembly with 2 assembly hinges
- Stability ensured by protective plastic feet Large choice of accessories for all your needs:
- Protective feet, spotlights, mountings for panels or photos, etc.

Algeria

APIS INDUSTRY ALGERIE
Tel : +213 (0)23571260
contact@apisindustry.com

Germany

AR CADDIE
DEUTSCHLANDGMBH
Tel : +49 (0)71316452716
deutschland@caddie.com

Saudi Arabia

Mr Mohammed Barakat
Tel : +96 (0)6503121575
mohbrkt@yahoo.com

Spain

CARTTEC
Tel : +34 (0)916574011
info@carttec.com

Hungary

ROTTE
Tel : +36(0)309141465
gabriella.illes@rotte.hu

Israël

Yail Noa
Tel : +972 (0)55509148
sales@yail-noa.co.il

Swiss

HLD CLEAN CONSULT SA
Philippe Lac
Tel : +41(0)327557353
p.lac@hld.ch

**PCM HABILCLASS**

contact@pcmhabilclass.com
10 rue de Paris
28150 Ouarville
Tel. +33 (0)2 37 18 01 21
Fax +33 (0)2 37 22 17 39
www.pcmhabilclass.com

Most of our models are patented or protected by registered trademarks in France and worldwide. We reserve the right to make any modifications to our items that we see fit, without prior notice.

MEDI.CADDIE®